

Bluebot: Arduino-Based Obstacle-Detection And Voice-Controlled Robot

M Seshu Bhavani¹, Ch Kaartheeka², S Sravani³, M V S Darshitha⁴

¹Associate Professor; Department Of Computer Science And Engineering (Ai&MI) Bhoj Reddy Engineering College For Women Hyderabad India

^{2,3,4}B.Tech Students; Department Of Computer Science And Engineering (Ai&MI) Bhoj Reddy Engineering College For Women Hyderabad India

Mail Id; kaarthi1801@gmail.com², shravanisiddamshetti@gmail.com³, malisettydarshitha@gmail.com⁴

Abstract

This paper presents BlueBot, an Arduino-based intelligent robotic platform designed for real-time obstacle detection and user-interactive control. The robot continuously monitors its surroundings using an ultrasonic sensing module that measures the distance to nearby objects and enables the system to detect obstacles and avoid potential collisions. Along with autonomous environmental sensing, BlueBot allows users to control the robot through both manual commands and voice instructions via a Bluetooth-enabled smartphone application. The system integrates multiple hardware components, including an Arduino Uno microcontroller for processing, an HC-05 Bluetooth module for wireless communication, and an L298N motor driver to control the robot's movement. These components work together to create a responsive platform capable of receiving remote commands while simultaneously analyzing environmental data. By combining sensor-based obstacle detection with wireless voice and manual control, the proposed system demonstrates an effective implementation of embedded systems and robotic interaction. The platform also serves as a practical educational tool for learning concepts related to the Internet of Things (IoT), robotics, and embedded programming. BlueBot provides a safe and interactive environment for experimentation while illustrating how sensing, communication, and control technologies can be integrated into a compact robotic system.

Keywords

Arduino Uno, Obstacle Detection Robot, Ultrasonic Sensor, Bluetooth Communication, Voice-Controlled Robot, L298N Motor Driver, Embedded Systems, Internet of Things (IoT), Mobile Robot Control.

INTRODUCTION

BlueBot is an intelligent robotic system developed using the Arduino platform to integrate environmental sensing with interactive user control. The robot employs an ultrasonic sensor to continuously monitor its surroundings and measure the distance to nearby objects. This sensing capability enables the system to identify obstacles in real time and alert the user when objects are detected within a predefined range. Although the robot does not automatically change its direction, the detection mechanism helps the user operate the system more

safely by providing awareness of the surrounding environment. In addition to environmental monitoring, BlueBot allows users to control its movements through both manual commands and voice instructions using a Bluetooth-enabled smartphone application. The communication between the mobile device and the robot is handled by the HC-05 Bluetooth module, which ensures reliable wireless connectivity. Motor operations are controlled through the L298N motor driver, which manages the movement of the robot's motors and enables directional commands such as forward, backward, left, and right.

Existing System

Many robotic systems developed for educational and experimental purposes focus primarily on either Bluetooth-based manual control or basic obstacle detection using sensors. Bluetooth-controlled robots enable users to navigate the robot through smartphone applications, allowing convenient remote operation. However, such systems typically lack environmental sensing capabilities, which makes them vulnerable to collisions when operating in dynamic or unfamiliar surroundings. The separation between user-controlled navigation and sensor-based environmental awareness restricts the overall functionality of many existing robotic systems. Without integrating both features within a single platform, these systems offer limited engagement and reduced practical value for educational or experimental use.

Proposed System

To address the limitations of existing systems, the proposed robotic platform, BlueBot, integrates obstacle detection with real-time manual and voice-based user control. The system is built around the Arduino Uno microcontroller, which serves as the central processing unit responsible for coordinating sensing, communication, and motor control functions. An HC-SR04 ultrasonic sensor is used to measure the distance between the robot and nearby objects, allowing the system to detect obstacles in its operating environment. Wireless communication between the robot and the user is achieved using the HC-05 Bluetooth module, which connects the robot to a smartphone application. Through this application, users can issue movement commands either manually or through voice input. The L298N motor driver controls the motors that drive the robot,

ensuring stable and precise movement in response to user commands.

LITERATURE SURVEY

In recent years, robotics has experienced significant progress due to advancements in embedded systems, sensor technologies, and wireless communication. These developments have enabled the creation of intelligent robotic platforms capable of interacting with users while performing tasks within dynamic environments. Voice-controlled robots integrated with obstacle detection systems represent an important step toward intuitive human-robot interaction and safer autonomous operation. Such systems combine technologies including speech recognition, microcontroller-based processing, wireless communication, and sensor-based environmental monitoring. Voice recognition allows users to interact with machines using natural language, improving accessibility and ease of use. Meanwhile, Bluetooth communication provides a reliable and low-cost wireless interface that enables mobile devices to control robotic platforms. Obstacle detection mechanisms, commonly implemented using ultrasonic sensors, further enhance the safety and efficiency of robotic systems by identifying objects within the robot's path. Together, these technologies contribute to the development of intelligent robots capable of both user-guided and sensor-assisted operation. The following section reviews several research works that have influenced the design and development of the proposed BlueBot robotic system.

Review of Literature

Several studies have explored the development of voice-controlled robotic systems using embedded platforms such as Arduino. Saravanan et al. (2020) introduced a voice-operated robotic vehicle that receives speech commands through an Android application. These commands are transmitted via Bluetooth to an Arduino microcontroller, which interprets the instructions and controls the motors through a motor driver module. The study demonstrated that integrating wireless communication with speech processing can significantly improve human-robot interaction and simplify robot control mechanisms. Similarly, Teeda et al. (2024) investigated the application of speech recognition technology in robotic systems. Their work focused on converting spoken instructions into digital signals using a smartphone interface. The microcontroller processes these signals and triggers predefined robotic actions. The authors highlighted the importance of real-time processing and accurate interpretation of voice commands in improving the efficiency and responsiveness of such systems. Ahmmed (2024) proposed an Arduino-based multifunctional robot controlled through Bluetooth communication. The system architecture

consisted of a microcontroller, communication module, and motor driver, enabling wireless control of the robot through a mobile device. The research emphasized the advantages of Bluetooth technology, particularly its low power consumption and ease of implementation for short-range wireless communication in robotic applications. Research published in the International Journal of Engineering Research and Technology (IJERT) examined the use of voice recognition techniques in surveillance robots. In this approach, speech commands are processed and converted into electrical signals that can be interpreted by the robotic controller. The robot then executes actions such as movement or monitoring based on the recognized commands. The study demonstrated the potential of voice-enabled robotics in security and surveillance environments. Another study published in IJRASET presented a robotic system controlled through smartphone-based voice commands. In this system, the Bluetooth module acts as a communication bridge between the mobile application and the robot. The Arduino microcontroller receives the transmitted signals and controls motor operations accordingly. The research highlighted that such systems are relatively simple to implement and cost-effective, making them suitable for educational and experimental applications.

Life Cycle Model

The development of the BlueBot system follows the Waterfall software development model, which is a structured and sequential approach to system design and implementation. In this model, each phase of development is completed before proceeding to the next stage, ensuring a systematic progression from requirement identification to final deployment. During the requirement analysis phase, the primary system features such as Bluetooth communication, voice command processing, and obstacle detection capabilities are identified. The system design phase focuses on developing the hardware architecture and software structure required to support these functionalities. The implementation phase involves writing the Arduino program and integrating hardware components including the Bluetooth module, ultrasonic sensor, motor driver, and motors. Once the implementation is completed, the system undergoes testing to verify the proper operation of movement commands, wireless communication, voice input processing, and obstacle detection functionality. After successful testing, the robot is deployed for real-time operation. The final maintenance phase involves monitoring system performance, correcting errors, and updating system features or configurations when necessary.

Block Diagram

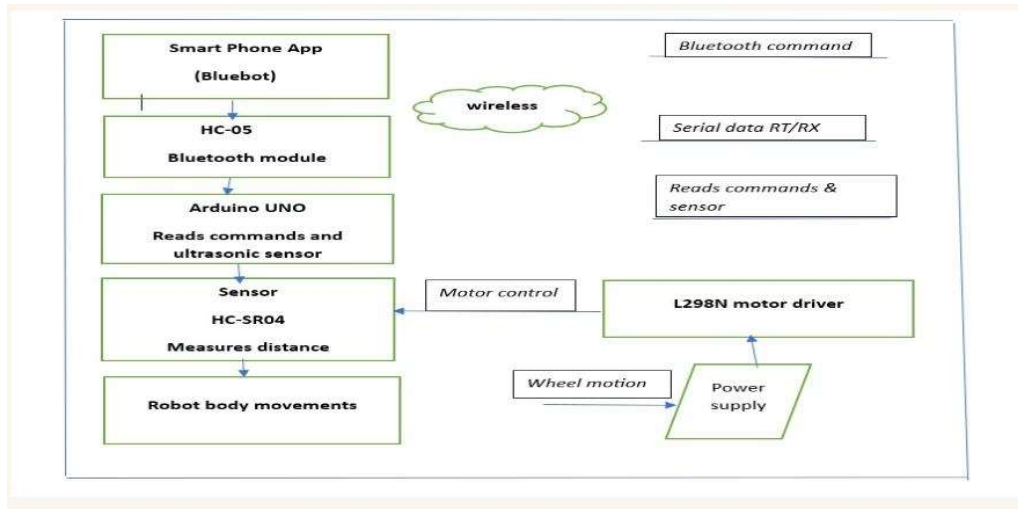

Block Diagram

The block diagram represents the overall functional structure of the BlueBot system. It illustrates how the major hardware components are interconnected and how data flows between them. In this design, the smartphone application acts as the primary input interface through which users send voice or manual commands. These commands are transmitted to the HC-05 Bluetooth module, which converts the wireless signals into serial data that can be interpreted by the Arduino microcontroller. The Arduino Uno functions as the central controller that processes both the user commands and the data received from the ultrasonic sensor. Based on the interpreted instructions, the microcontroller sends control signals to the motor driver module. The motor driver then regulates the voltage and current supplied to the DC motors, allowing the robot to move in different directions such as forward, backward, left, or right. At the same time, the ultrasonic sensor continuously monitors the surrounding environment and provides distance measurements to the Arduino. This integrated structure allows the robot to respond dynamically to both user instructions and environmental conditions.

Data Flow Diagram

The Data Flow Diagram (DFD) illustrates the logical movement of information within the BlueBot system. It shows how commands, sensor data, and control signals travel between different modules. The process begins when the user provides a command through the smartphone application. This command is transmitted wirelessly through the Bluetooth module and received by the Arduino microcontroller. Once the command is received, the Arduino processes the data and determines the appropriate movement action. Simultaneously, the ultrasonic sensor sends distance measurements to the controller, allowing the system to detect nearby obstacles. Based on this combined information, the Arduino generates control signals that are forwarded

to the motor driver. The motor driver then activates the motors according to the required direction and speed. The DFD therefore helps visualize how data is processed and transformed within the robotic system from input to final mechanical action.

System Components

The BlueBot robotic system consists of several hardware components that collectively enable sensing, communication, control, and mobility. Each component performs a specific function and works together with other elements to ensure efficient operation of the robot. The combination of these components allows the system to receive user commands, process them through the microcontroller, detect environmental obstacles, and perform controlled movement.

HC-05 Bluetooth Module



Fig. 1 HC-05 Bluetooth Module

The HC-05 Bluetooth module is a wireless communication device used to establish a connection between the robot and external devices such as smartphones. It operates using the Serial Port Protocol (SPP), which allows data to be transmitted and received through serial communication. The module typically supports communication within a range of approximately ten meters. It can operate in both master and slave modes, providing flexibility in establishing wireless connections. Because of its simplicity and compatibility with microcontrollers, the HC-05

module is widely used in robotics, home automation, and embedded system projects.

Berg Strip



Fig. 2 Berge Strip

A Berg strip, also known as a header pin connector, is used to create electrical connections between electronic components on a circuit board. It allows wires to be easily attached or removed without soldering. In serial communication systems, the RX (Receive) and TX (Transmit) pins are commonly used to send and receive data between devices such as the Arduino and the Bluetooth module. Berg strips are available in male and female forms, making them useful for flexible hardware connections during prototyping and testing.

Arduino Uno Controller

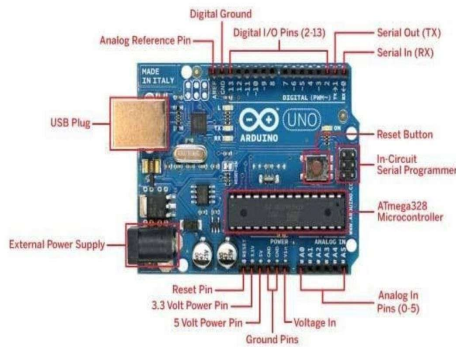

Fig. 3 Arduino Uno Controller

The Arduino Uno is a microcontroller board based on the ATmega328P processor and serves as the central controller of the BlueBot system. It provides multiple digital and analog input/output pins that allow sensors, communication modules, and motors to be connected. The board is programmed using the Arduino Integrated Development Environment (IDE) through a USB interface. Due to its simplicity, open-source architecture, and extensive community support, the Arduino Uno is widely used in robotics and embedded system applications. It also provides regulated power output and supports serial communication through dedicated RX and TX pins.

Ultrasonic Sensor



Fig.4 Ultrasonic Sensor

The ultrasonic sensor is responsible for detecting obstacles by measuring the distance between the robot and nearby objects. It operates by transmitting ultrasonic sound waves and measuring the time required for the reflected signal to return. Based on this time difference, the sensor calculates the distance to the object. The sensor typically consists of four pins: VCC, GND, TRIG, and ECHO. It is capable of measuring distances ranging from approximately 2 centimeters to 400 centimeters, making it suitable for obstacle detection and navigation in robotic systems.

Motor Driver Shield



Fig.5 Motor Driver Shield

The motor driver module is an electronic interface that enables the microcontroller to control DC motors safely and efficiently. In the BlueBot system, an L293D motor driver shield is used to regulate motor operation. Microcontrollers alone cannot supply the current required to drive motors directly, so the motor driver acts as an intermediary between the controller and the motors. It utilizes an H-bridge circuit to control the direction of motor rotation and allows speed control using Pulse Width Modulation (PWM) signals. The L293D driver can control two DC motors simultaneously and is widely used in robotic movement control systems.

Jumper Wires



Fig.6 Jumper Wires

Jumper wires are used to establish electrical connections between different components within the circuit. They connect modules such as the Arduino controller, Bluetooth module, ultrasonic

sensor, and motor driver. Jumper wires are available in male-to-male, male-to-female, and female-to-female configurations, allowing flexible connectivity during circuit assembly. Since they do not require soldering, they are particularly useful during the prototyping stage of electronic projects.

Wheels and DC Motors



Fig.7 Wheels and DC Motor

DC motors provide the mechanical power required for the movement of the robot. The motors are connected to the wheels, enabling the robot to move in various directions such as forward, backward, left, and right. The wheels help maintain stability and balance while the robot is in motion. They are typically made from materials such as rubber or plastic to provide adequate surface grip. Together, the motors and wheels form the primary mobility system of the BlueBot robot.

Lithium-Ion Battery



Fig.8 Lithium ion Battery

A lithium-ion battery serves as the primary power source for the BlueBot system. These batteries are rechargeable and provide high energy density while maintaining a compact and lightweight design. The battery supplies electrical power to the Arduino microcontroller, motor driver, Bluetooth module, and sensors. Lithium-ion batteries offer longer operating time compared to conventional batteries and can be recharged multiple times, making them suitable for portable robotic systems.

SPST Switch



Fig. 9 SPST Switch

The Single Pole Single Throw (SPST) switch is a basic electrical switch used to control the power supply of the robotic system. It contains one input

terminal and one output terminal, allowing the circuit to be either opened or closed. When the switch is in the ON position, the circuit is closed and electrical current flows to power the robot. When it is in the OFF position, the circuit is opened and the system is disconnected from the power source. SPST switches are commonly used in electronic devices to provide simple and reliable power control.

IMPLEMENTATION

Circuit Diagram

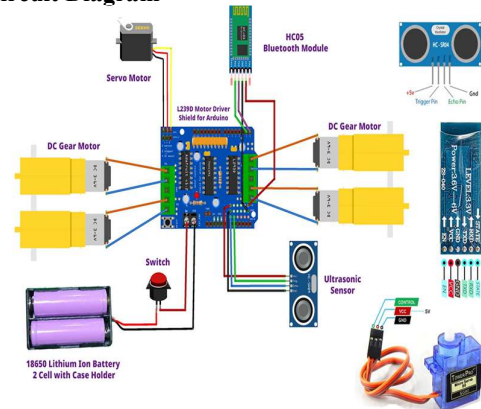

Fig 10 Circuit Diagram

The implementation of the BlueBot robotic system integrates embedded programming, wireless communication, and sensor-based monitoring to achieve voice-controlled navigation and obstacle detection. The circuit design connects the Arduino Uno microcontroller with the HC-05 Bluetooth module, ultrasonic sensor, motor driver module, DC motors, and power supply components. The Arduino functions as the central controller responsible for coordinating communication, sensing, and movement operations. Simultaneously, the ultrasonic sensor continuously monitors the environment to detect potential obstacles. The sensor emits ultrasonic waves and measures the time taken for the reflected waves to return, allowing the system to calculate the distance to nearby objects. If an obstacle is detected within a predefined safety threshold, the Arduino temporarily overrides the user command and stops or redirects the robot to avoid a collision. All hardware components are powered using a rechargeable battery source, enabling the robot to operate independently without requiring a wired power supply. This integrated circuit configuration ensures stable communication, responsive movement control, and safe navigation during operation.

Pseudocode / Algorithm

The program controlling the BlueBot robot follows a structured sequence of operations to manage communication, sensing, and motion control. Initially, the system performs hardware initialization, including setting up serial communication for Bluetooth connectivity, configuring the ultrasonic sensor pins, attaching the

servo motor, and setting the speed of the DC motors. After initialization, the system continuously listens for incoming commands from the Bluetooth module. When a command is received, the Arduino interprets the instruction and executes the corresponding action such as moving forward, moving backward, turning left, turning right, or stopping. While the robot is in motion, the ultrasonic sensor repeatedly measures the distance to nearby objects. If the measured distance falls below a predefined safety threshold, the system identifies the presence of an obstacle. In such cases, the Arduino temporarily stops the motors and scans the surrounding area using the servo-mounted ultrasonic sensor to determine the safest direction for movement. Based on the scanning results, the robot either changes direction or resumes forward movement once a clear path is detected.

The control loop continues to operate as long as the robot is powered on, ensuring continuous monitoring of user commands and environmental conditions. This algorithm enables the robot to respond dynamically to both user inputs and real-time sensor data, allowing safe and efficient navigation.

TESTING

Testing is a critical phase in the development of any robotic system, as it verifies whether the implemented design operates according to the specified requirements. In the case of the BlueBot system, which is an Arduino-based voice-controlled robot with obstacle detection capability, testing ensures that both the hardware and software components function correctly and reliably. Because the system interacts with real-world environments and processes user commands in real time, even minor errors may lead to incorrect robot movements, delayed responses, or failure in detecting obstacles. Therefore, a systematic testing process is essential to validate system behavior and improve operational safety.

Dimensions of Testing

Testing the BlueBot robotic platform involves evaluating multiple aspects of system performance and functionality. One important dimension of testing focuses on the different layers within the system architecture, including the input layer, control layer, and hardware layer. The input layer involves the mobile application that captures voice commands from the user, while the control layer processes these commands through the Arduino microcontroller. The hardware layer consists of components such as sensors, motors, and the motor driver. Testing across these layers ensures smooth interaction between user inputs, system processing, and mechanical output.

Another dimension of testing relates to the scale at which testing is conducted. This includes examining individual components through unit testing, evaluating groups of components through module

and integration testing, and assessing the complete system through system-level testing. Each stage verifies the performance of the robot at different levels of complexity.

Stages of Testing

Unit Testing

Unit testing involves evaluating each component of the BlueBot system individually to ensure that it functions correctly when provided with valid inputs. During this phase, the major hardware modules—including the Bluetooth module, Arduino microcontroller, ultrasonic sensor, and motor driver—are tested independently. For example, the Bluetooth module is tested to verify that it can successfully receive commands from the smartphone application. Similarly, the ultrasonic sensor is evaluated to confirm that it accurately measures distances and detects obstacles. The Arduino controller is tested to ensure that it correctly processes commands and generates appropriate output signals for motor control. Testing individual modules at this stage helps identify component-level issues before integrating them into the complete system.

Integration Testing

Integration testing evaluates how different components of the BlueBot system interact when combined. In this stage, multiple modules—including the Bluetooth module, Arduino controller, ultrasonic sensor, and motor driver—are connected and tested together to ensure proper communication and coordination. For instance, a voice command transmitted from the mobile application is received by the Bluetooth module and forwarded to the Arduino controller. The controller then processes the command and sends control signals to the motor driver, which activates the motors accordingly. At the same time, sensor readings are monitored to ensure that obstacle detection operates correctly during robot movement. Integration testing helps verify that data flows smoothly between system components without communication errors.

System Testing

System testing evaluates the BlueBot robot as a complete and fully integrated system. In this stage, all modules—including voice command input, Bluetooth communication, sensor monitoring, and motor control—are tested simultaneously. The objective is to ensure that the system operates according to the defined requirements and performs its tasks reliably. During system testing, the robot is tested in real-world scenarios where it receives voice commands, moves in different directions, and detects obstacles within its operating environment. This process helps confirm that all components work together effectively and that the robot behaves as expected under normal operating conditions.

Acceptance Testing

Acceptance testing determines whether the BlueBot system meets the expectations and requirements of

the intended users. During this stage, the robot is evaluated based on usability, reliability, and performance in practical scenarios. Testers or users operate the robot through the mobile application and verify that it responds correctly to voice commands and manual controls. They also assess whether the obstacle detection mechanism functions accurately and whether the robot moves safely without causing collisions. Feedback collected during this phase helps determine whether the system is ready for deployment and real-world use.

Test Cases

Test cases are designed to validate the functional behavior of the BlueBot robotic system under various operational scenarios. These cases evaluate the robot’s response to different voice commands, verify motor movements in multiple directions, and assess the accuracy of obstacle detection. For example, test cases may include verifying whether the robot moves forward when a specific command is issued, whether it stops when the “stop” command is received, or whether it halts movement when an obstacle is detected within the safety range. Each test case records the input command, expected behavior, and actual system response to ensure that the robot performs according to the specified design requirements.

Screenshots

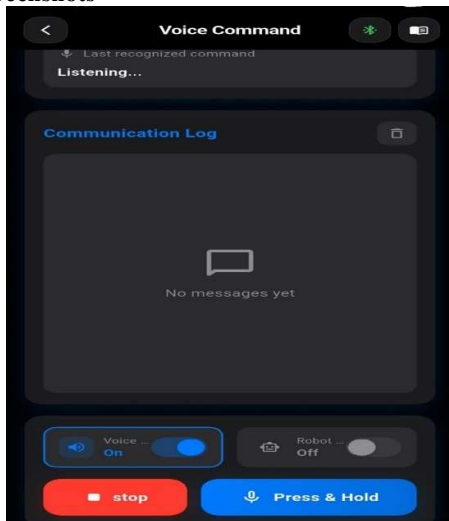

Fig 1 BLUETOOTH CONNECTION AND BLUEBOT APP

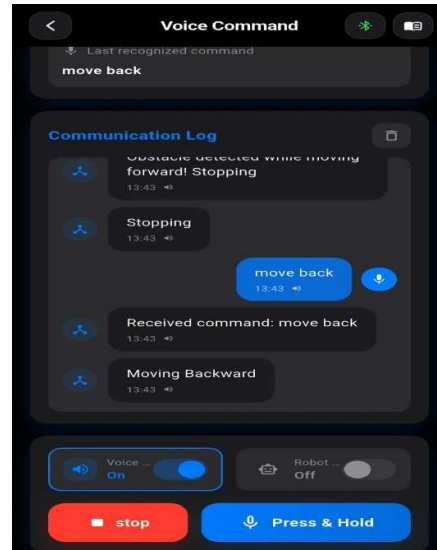

Fig 2 MOVE FORWARD AND BACK VOICE COMMAND

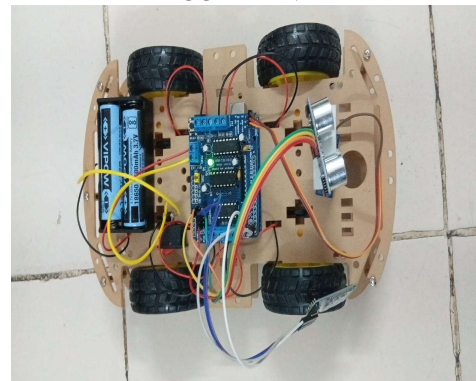

Fig 3 BLUEBOT ROBOT

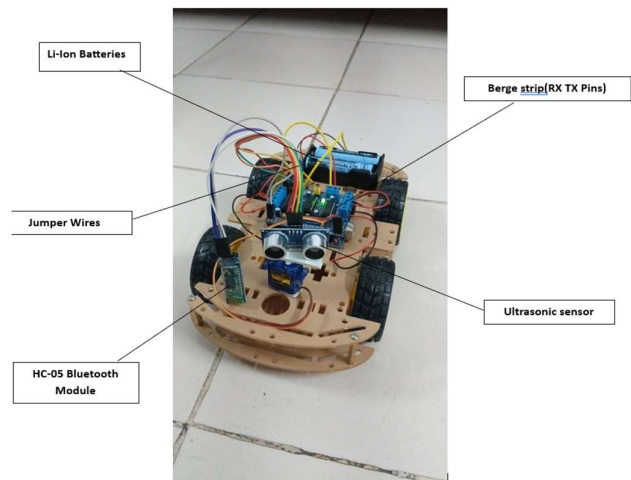

Fig 4: BLUEBOT ROBOT PARTS IDENTIFICATION

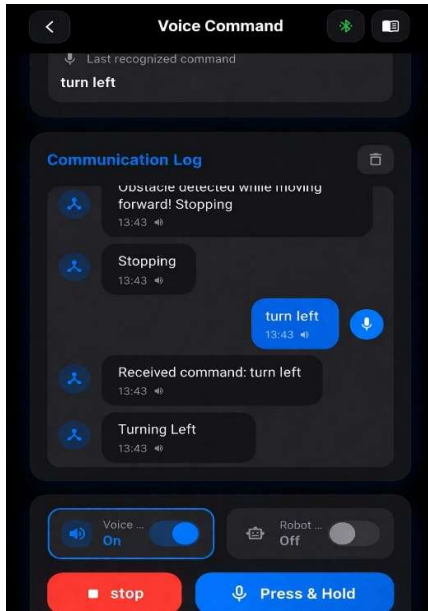

Fig 5: LEFT AND RIGHT VOICE COMMANDS

CONCLUSION

The BlueBot robotic platform demonstrates the successful development of an interactive robotic system built on the Arduino microcontroller platform. The project integrates several hardware and software components—including ultrasonic sensors for environmental sensing, DC motors with motor drivers for motion control, and Bluetooth communication modules for wireless connectivity—into a unified system capable of responding to user commands and monitoring its surroundings. By combining these technologies, the robot can detect nearby obstacles and respond to voice or manual commands received through a smartphone application. The system highlights the practical implementation of embedded programming and real-time sensor processing within a robotic platform. The ultrasonic sensor continuously measures the distance between the robot and surrounding objects, enabling the system to detect potential obstacles and respond appropriately. At the same time, the Bluetooth communication interface allows users to control the robot remotely using voice commands or manual instructions, providing a flexible and intuitive interaction method. This combination of environmental sensing and user-driven control demonstrates how multiple technologies can be integrated to create intelligent and responsive robotic systems. Beyond its technical functionality, the BlueBot project serves as an effective educational tool for exploring fundamental concepts in robotics, embedded systems, and Internet of Things (IoT) communication. Through the design and implementation of the robot, users gain hands-on experience with hardware integration, microcontroller programming, and wireless communication technologies. The project

encourages practical learning by allowing students and beginners to experiment with system design, troubleshoot hardware and software issues, and explore innovative modifications.

FUTURE SCOPE

Although the BlueBot robotic system successfully demonstrates the integration of obstacle detection and voice-controlled navigation, several opportunities exist for future enhancement and expansion. Further improvements can focus on increasing system intelligence, improving user interaction, and expanding the robot's capabilities for more advanced applications. One possible area of development involves implementing advanced control mechanisms. Future versions of the system could incorporate gesture recognition, improved speech recognition algorithms, or artificial intelligence-based voice processing to enhance command accuracy and flexibility. These technologies would allow the robot to interpret user instructions more effectively and provide a more natural interaction experience. Another potential improvement is the development of a dedicated mobile application for controlling the robot. A customized application could provide an improved graphical interface, enable additional control features, and display real-time system information such as sensor readings, movement status, and battery levels. Such an application would enhance usability and provide better monitoring. BlueBot system also allows for the addition of new sensors and modules to enhance performance. Future designs could incorporate cameras for visual navigation, GPS modules for location tracking, or infrared sensors for improved obstacle detection. These enhancements would allow the robot to operate more effectively in complex environments and support advanced navigation capabilities.

REFERENCES

- [1] M. Saravanan, R. Prakash, S. Karthik, and S. Rajkumar, "Arduino Based Voice Controlled Robot Vehicle," 2020. Available: <https://www.researchgate.net/publication/348113070>
- [2] V. Teeda, A. Kumar, and R. Singh, "Voice Controlled Robot Using Arduino," 2024. Available: <https://arxiv.org/abs/2402.03803>
- [3] F. Ahmmed, "Arduino-Controlled Multi-Function Robot with Bluetooth," *International Journal of Robotics and Control Systems*, 2024. Available: <https://pubs2.ascee.org/index.php/IJRCS/article/view/1517>
- [4] A. Kumar, S. Verma, and P. Sharma, "Voice Controlled Robotic Car Using Arduino," Available: <https://www.researchgate.net/publication/361809398>

- [5] S. Sharma, R. Gupta, and A. Singh, "Voice Controlled Robot," *International Journal for Research in Applied Science and Engineering Technology (IJRASET)*. Available: <https://www.ijraset.com/research-paper/voice-controlled-robot>
- [6] R. Singh, P. Mishra, and K. Yadav, "Voice Recognition Robot for Surveillance," *International Journal of Engineering Research and Technology (IJERT)*. Available: <https://www.ijert.org/voice-recognition-robot-for-surveillance>
- [7] "Voice Recognition and Obstacle Detection Robot," Available: <https://www.scribd.com/document/645251680>
- [8] P. Verma, A. Bansal, and R. Jain, "Review on Voice Controlled Home Automation System," *International Journal of Engineering Research and Technology (IJERT)*, 2023. Available: <https://www.ijert.org/review-on-voice-controlled-home-automation-system>
- [9] "Voice Controlled Robotic System," Available: <https://www.engpaper.com/ece/voice-controlled-robotic-system.html>
- [10] A. Sharma, R. Mehta, and K. Patel, "Voice Controlled Assistive Robot," 2023. Available: <https://arxiv.org/abs/2309.11594>
- [11] Arduino, "Arduino Official Documentation." Available: <https://www.arduino.cc/en/Guide>
- [12] IEEE, "Bluetooth Communication Basics." Available: <https://ieeexplore.ieee.org/>
- [13] S. Patel and R. Shah, "Ultrasonic Sensor Applications in Robotics," *International Journal of Engineering Research and Technology (IJERT)*. Available: <https://www.ijert.org/>
- [14] R. Jones and M. David, "Embedded Systems in Robotics," *ScienceDirect*. Available: <https://www.sciencedirect.com/>
- [15] "Voice Controlled Automation Systems," Available: <https://www.researchgate.net/>
- [16] K. Patel and A. Desai, "Arduino Obstacle Avoidance Robot," *International Journal of Engineering Research and Technology (IJERT)*. Available: <https://www.ijert.org/>
- [17] P. Soni and A. Bansal, "Wireless Robot Control Using Bluetooth," *International Research Journal of Engineering and Technology (IRJET)*. Available: <https://www.irjet.net/>
- [18] IEEE, "Smart Autonomous Robot," Available: <https://ieeexplore.ieee.org/>
- [19] R. Kaur and D. Aggarwal, "Bluetooth Based Robot Control System," *International Journal of Advanced Research in Computer Science*. Available: <https://www.ijarcs.info/>
- [20] Y. Zhang and H. Li, "Robotics Automation Using Arduino," *Springer*. Available: <https://link.springer.com/>
- [21] MDPI, "Voice-Controlled Embedded Systems," Available: <https://www.mdpi.com/>
- [22] Y. Zhang and H. Li, "Survey on Voice Control Systems in Robotics," *Springer*. Available: <https://link.springer.com/>