



IJITCE

ISSN 2347- 3657

International Journal of Information Technology & Computer Engineering

www.ijitce.com



Email : ijitce.editor@gmail.com or editor@ijitce.com

Comparison of different techniques to improve the Input Power factor Of rectifiers

Mr. Y .Davidu¹, N.Gnanendra Sai Rohith ², P.Naveen ³,

Abstract:

At the input of AC-DC switching mode power supply, we often use a full wave rectifier and a parallel capacitor to get the direct voltage smooth and level. Because rectifier is non-linear and filter capacitor is an energy-stored component, the combination of those two will make the input alternating current distort greatly. Please see Fig.1. “t” for time (Seconds) ; “Vi” for electrical input voltage (Volts) and “ii” for electrical input current (Amperes).

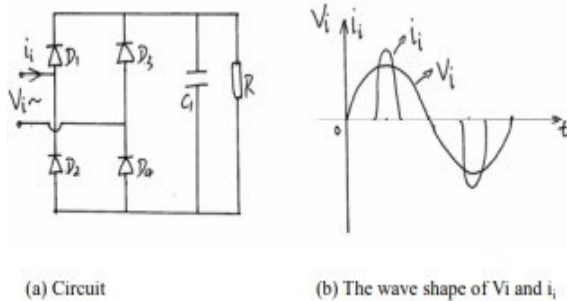

There are several harmonic waves present in the input pulse shape current. This will significantly lower the power factor. In addition, a high current harmonic emission will cause the circuit to get out of order and

distort the voltage contour. We must take action to restrict the input harmonic current in order to increase the input power factor and lessen the pollution generated by the AC-DC converter's input harmonic current. I want to compare and outline the various power factor correction techniques in this study. II. There are two popular approaches to raise the AC-DC converter's input power factor and lower its input harmonic current. Employing a standard "L" filter: To create a L filter, there are two methods: either attach a L filter at the rectifier's alternating side, or put an inductor between the rectifier and the filter capacitor C. Of course, you can combine these two ways together, and this will be more effective. Please see Fig.2. “t” for time (Seconds) ; “E” for electrical voltage (Volts) and “i2” for electrical current (Amperes).

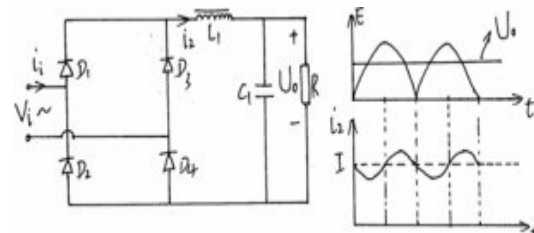

Fig. 2: Rectifier and “L” filter

Assistant Professor ¹,
Department of EEE,

This manner, as opposed to the pulsing current flow required by the capacitor input filter, the input inductor L_1 permits a constant flow of current from the diodes. In this case, the current I_L is undoubtedly continuous. As a result, the power factor will increase. This method's benefits include minimal EMI, simplicity, affordability, and reliability. The drawbacks of this approach are significant, weighty, and comparatively challenging to achieve a power factor greater than 0.9. Its function is related to changes in frequency, load, and input voltage. The current between the inductor and the capacitor is highly charged and discharged. It is used in scenarios like frequency converters when the input power factor need is not particularly high. 2. A DC-DC switching converter may be connected between the rectifier and the load via active power factor correction (APFC). By using current feedback technology, we can thus make the wave pattern of input current i_L resemble that of input sine voltage. Thus, we are able to raise the power factor to 0.99 or above.

Its advantages are that it can achieve high power factor: 0.97~0.99, very low total harmonic distortion, stable output 2 voltage, small volume and low weight. Its disadvantages are that its electrical circuit is complex; it is expensive and its EMI is high. Certainly, these will make the efficiency reduce a little. III. Boost power factor corrector Theoretically, each kind of DC-DC converter, such as Buck, Boost, Flyback and Sepic can be used as the main circuit of PFC, but the Boost converter is used widely because of its special advantages. 1: The theory of Boost power factor corrector (Average current control). Please see Fig.3

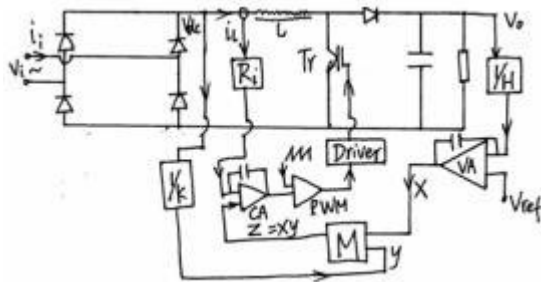

Fig. 3: Boost APFC circuit---average current control

The current error amplifier, or CA, receives the signal $i_L R_i$, which is acquired by directly measuring the inductor current (i_L). The output signal of multiplier "M," "Z," which has two input signals—X, the error signal of output voltage V_o/H and standard voltage V_{ref} , and Y, the measured value of V_{dc} ($Y=V_{dc}/K$)—is the current standard of CA. The input sine voltage V_i 's full wave rectified value is V_{dc} . As a result, the double half wave sine voltage equals the standard current. The current error amplifier, or CA, will averagely handle the variance of the high frequency signal of the input inductor current, I_L , after comparing it to the standard current. The PWM will deliver the correct driving signal to the power switching tube T_r and identify the proper "D" of T_r tube after comparing the amplified average current error signal with the saw tooth slope wave. Ultimately, the input power factor will be enhanced to almost "1" and the existing inaccuracy will be swiftly and precisely repaired. The inductor current's (i_L) wave form is seen in Fig. 4. "t" stands for time in seconds, and " i_L " for

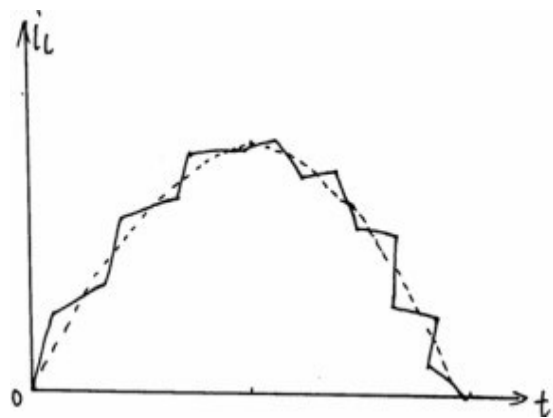

Fig. 4: The wave shape of i_L

2: The Boost APFC Controlling Method In general, there are three typical ways to manage Boost APFC. These are current peak value control, average current control, and hysteretic current control. because the

discussion above analyzes the average current control. In the conversation that follows, I will present the other two control strategies. The Boost APFC circuit using the current peak value control approach is shown in Figure 5.

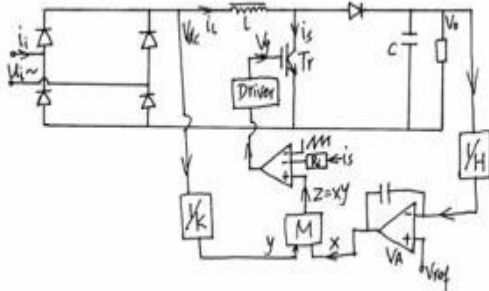

Fig. 5: Boost APFC --- current peak control

Here, the current of T_r is measured and its corresponding value $i_s R_i$ is sent to the current comparer. The current standard is given by the output of the multiplier: $Z = XY$. There are two input signals for the multiplier; one is X , the error signal between the output voltage V_o/H and the standard voltage V_{ref} ; the other is Y , the measured value of the voltage V_{dc}/K . V_{dc} is the full wave rectified value of sine voltage V_i . Therefore, the current standard is double half wave sine 3 voltage. Let the peak value of the input current i_L trace the wave shape of input voltage V_{dc} so as to make the input current have the same phase with input voltage. In this way, it can make the input power factor nearly be equal to 1. Figure 6 is the wave shape of high frequency modulated inductor current wave shape by the way of PWM in half cycle of working period. "t" for time (Seconds) and "i L" for electrical current.

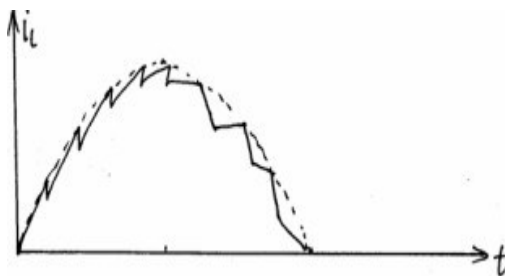

Fig. 6: The inductor current wave shape---

current peak value control When T_r turns on, the inductor current will increase. When it reaches its peak value (To be controlled by the current standard value), the comparer will send out signal to turn off T_r and the inductor current will begin to decline. At the next on-off cycle, T_r will turn on again. It will be on and off in this way periodically. The main disadvantage for this method is that the error between the peak value of the inductor current i_L and its average value is sometimes too high to satisfy the requirements of low total harmonic distortion. Another problem is that the current peak value is very sensitive to electrical noise. Its working mode is CCM only. Figure 7 shows the Boost PFC circuit with the hysteric current control

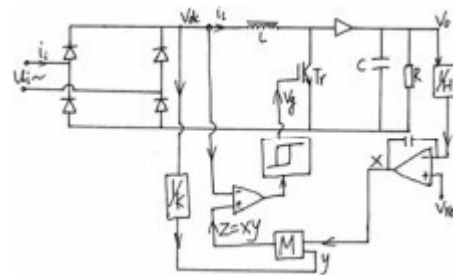
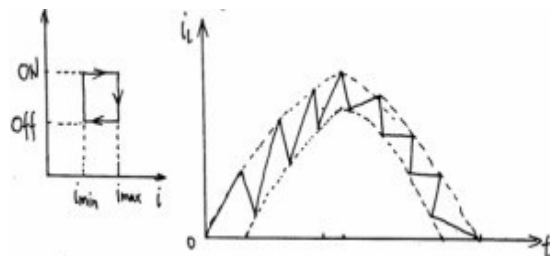

Fig. 7: Boost PFC circuit --- Vref hysteric current contro

By splitting the observed input voltage V_{dc} in this manner, two standard currents are produced. The greatest current standard value is represented by one, and the lowest current standard value by another. T_r will activate and the inductor current will start to increase when the inductor current (i_L) drops below the minimum value i_{min} . T_r will cut off and the current will start to decrease once again when the inductor current reaches its maximum value, or i_{max} . Figure 8 illustrates the wave form of the inductor current in this manner. "t" stands for time (in seconds) and "i L" for current (in amps) in electricity.



The primary drawback of this approach is that the load has an impact on the frequency. Given the broad range of variations in the on-off frequency, the output filter must be designed with the lowest on-off frequency in mind. As such, it is not feasible to get the design with the lowest weight and volume. Having conducted several studies, I have come to the conclusion that the average current control yields the best results due to its low overall harmonic distortion and ability to be noise-insensitive. Undoubtedly, this method yields a less error between the average current and the peak value of the inductor current (i.e., L) than the other two. Both continuous and discontinuous current modes may be used with the average current control. The current peak value of the other two is noise-sensitive and may only be utilized in continuous current mode.

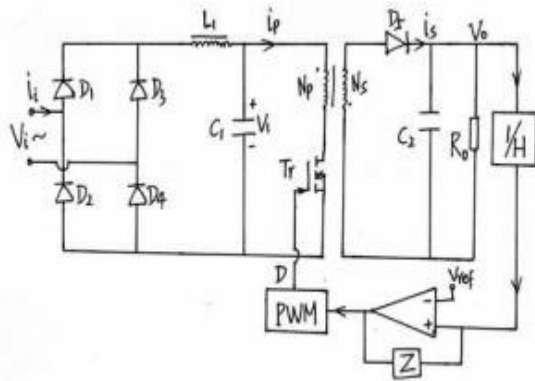

Fig.9: Flyback power factor corrector circuit

We can prove that the DC-DC converter in the Flyback converter is equivalent to a Loss Free Resistor controlled by D (ton/T_s) if the Flyback converter works in DCM style. Therefore, we can make its input power factor nearly equalize to “1” by using this simple voltage control method. In order to make it easy to be understood, I will analyze the working process of this converter in detail. In order to be convenient, I write: $n=N_p/N_s$; I assume the inductance of the primary side of the transformer as “ L_p ” and the inductance of the secondary side of the transformer as “ L ”. Apparently, $L_p = n^2 L$

$$I_p = \frac{V_1}{L_p} t \quad (1)$$

Therefore, at the end of this period of time, the peak value of “ i_p ” is:

$$I_{pm} = \frac{V_1}{L_p} DT_s \quad (2)$$

During the period of $[DT_s, (D+D_2)T_s]$, T_r is “OFF” and the energy stored in transformer inductance will release through diode D_5 to the output load. Because the output voltage V_o is constant, the electrical current of the secondary side of the transformer “ i_s ” will decline as the time passes by the slope of “ $-V_o/L$ ”. “ $D_2 T_s$ ” is the period of time for diode D_5 is “ON”. We assume the peak value of “ i_s ” is “ I_{sm} ”. Because “ $I_{pm}N_p = I_{sm}N_s$ ”, we can get the peak value of “ i_s ” as:

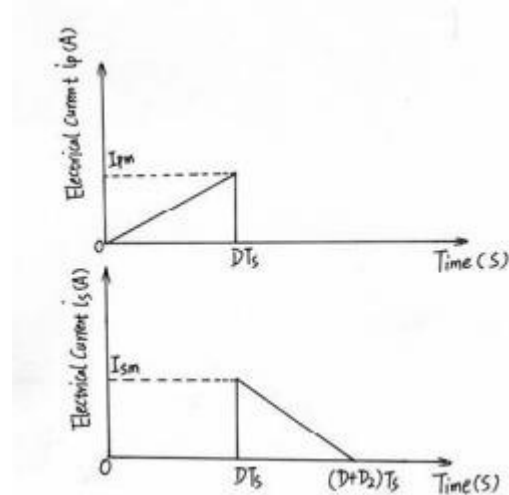

Fig.10: The wave shape of i_p and i_s

$$I_{p(\text{avg})} = \frac{1}{T_s} \int_0^{T_s} i_p dt$$

$$= \frac{D^2 T_s V_1}{2n^2 L} \quad (4)$$

So, DC-DC Flyback converter is a controllable Loss Free Resistor when it works in DCM situation and its input power factor is nearly equal to “1”. Compared with CCM Boost power factor corrector, the DCM Flyback power factor corrector has the following

advantages: (1) Its control is very simple, its input electrical current automatically has the sinusoidal shape. (2) Its output voltage V_O can be more than or less than the peak value of V_i . (3) We need not add the slope compensator for it. The DCM Flyback power factor corrector is often used when the output power of the converter is less than 150 Watt.

REFERENCES

1. [1] Michail A. Slonim, P.P. Biringer: "Harmonics of Cyclo Converter Voltage Wave Form (New Method of Analysis)", IEEE Trans. Ind. Electron. Contr. Instrum. Vol. IECI-F27, NO.2, May, 1980
2. [2] Ding Dao Hong: "Power Electronic Technology", Aeronautical Industry Press, 1992.
3. [3] G. Hua et.al. , A New Class of ZVS-PWM Converters, High Frequency Power Conversion Conference Proceedings, 1991, 244-251
4. [4] R. A. Fisher et.al. , A 500 KHZ 250W DC/DC Converter with Multi-outputs Controlled by Phase Shifted PWM and Magnetic Amplifiers, HFPC Proceedings 1988, 100-110
5. [5] F.Caricchi, F.Crescimbeni, F.G.Capponi, L Solero, " Study of Bi-directional Buck-boost Converter Topologies for Application in Electrical Vehicle Motor Drives," Applied Power Electronics Conference and Exposition, 1998 287-293
6. [6] V.Vlakovic, J.A.Sabate et al, " Small-Signal Analysis of the Zero-Voltage-Switched Full-Bridge PWM Converter," 1990 VPEC Seminar Proceedings (USA), 19-29
7. [7] Ivo Barbi et.al. , "Buck Quasi-Resonant Converter Operating at Constant Frequency; Analysis, Design and Experimentation," IEEE Trans. on Power Electronics, 276-283, Vol.5, No.3, 1990
8. [8] J.C. Mercieca, J.N. Verhille, A. Bouscayrol, " Energetic Macroscopic Representation of a subway traction system for a simulation model", Proc. of IEEE- ISIE'04, Ajaccio (France), May 2004, CD-ROM.
9. [9] A. Bouscayrol, " Modelling and control of multi-machine multi-converter systems", (text in French), Habilitation a Diriger les Recherches, University of Lille I, Lille