



IJITCE

ISSN 2347- 3657

International Journal of Information Technology & Computer Engineering

www.ijitce.com



Email : ijitce.editor@gmail.com or editor@ijitce.com

The Five-Level Inverter Modelling and Analysis for Renewable Energy Sources

Dr.SRIKANT DASH, PhD,

ABSTRACT:

A brand-new seven-degree inverter and dc/dc power converter are included in this solar strength measuring gadget. The dc/dc electricity converter incorporates a dc-dc beautify converter and a transformer to change the voltage from the solar cell option's output into several, independent voltage resources. This novel seven-stage inverter is built using a capacitor selection circuit and a full-bridge power converter wired in series. The output of the solar photovoltaic panel device is fed directly into a maximum power point tracking (MPPT) regulation set in order to extract the maximum possible amount of energy from the solar photovoltaic device. This setup consists of a dc-dc energy converter and a nine-stage inverter. This state-of-the-art seven-level inverter is built with a capacitor preference circuit, much as a full bridge power inverter. The two dc/dc power converter output voltage sources are transformed into a three-level dc voltage by the capacitor choice circuit, and then this voltage is further transformed into seven levels by the full-bridge converter. The suggested system provides sinusoidal results in the present day that stay in phase with the application voltage and are supplied directly into the power grid.

KEY WORDS

PV Array, Maximum Power Point Tracker, Photovoltaic (PV) Panels, Multilevel Inverter, Seven-Level Inverter, Direct Current (DC) to Alternating Current (AC) Converter. 1.

INTRODUCTION

Solar power is gaining traction as a viable source of energy due to its low environmental impact and the rising cost of conventional energy sources coupled with the falling costs of solar arrays. Grid-connected solar power technology systems rely on the electricity conversion interface to change the dc energy generated by a daylight-hours cellular array into an energy and then feed this ac energy into the power grid. In the energy conversion client interface, an inverter is essential for changing the dc energy to the ac electric powered powered electricity [1]. Given that the voltage produced by solar cells is rather low, a dc-dc power converter is used in a small-scale solar electric energy generation tool to increase the output voltage and conform to the dc bus voltage of the inverter. To prevent squandering the sun's mobile range's power, it's crucial that the power conversion consumer interface performs at a high level. [2] The worldwide issue of greenhouse gas emissions is directly related to the widespread usage of nonrenewable fuel sources. In addition, when the world's supply of nonrenewable fossil fuels dwindles, these fuels will become too expensive for

the average consumer to purchase [3, 4]. Therefore, solar energy is becoming more important as the price of fossil fuel electricity continues to rise and the cost of solar arrays continues to drop, producing a win-win situation.

The System's Intended Purpose:

The worldwide issue of greenhouse exhausts is directly attributable to the widespread use of fossil fuels. Furthermore, when fossil fuel reserves are exhausted in the future, the goods made from them will undoubtedly become more and more expensive over time. Given the rising expense of fossil fuel energy and the falling price of solar panels, it's clear that solar is becoming more important. Eventually, solar power may be widely implemented in residential settings, especially in the context of limited capacity allotted energy generating frameworks. Important to grid-connected solar power generation systems, the power conversion interface converts the dc electrical power produced by a sunlight cellular array into a/c power and then feeds this a/c power into the utility grid.

Professor, Department of Electronics Communication Engineering
Gandhi Institute For Technology, Bhubaneswar.

The inverter is a crucial component of the power conversion interface, since it converts the dc strength to the ac strength required by the air conditioner. Since the voltage produced by a sun cell array is often rather low, a dc—dc strength converter is typically used in a compact solar electrical energy generation equipment to boost the output voltage to a level where it can be used to direct the inverter's dc bus. The effectiveness of the power conversion interface is vital to ensuring that the energy harvested from the sun is used effectively. There is a power loss caused by the inverter's dynamic and passive tools and devices. Both transmission and transformation losses are accounted for in the total energy lost by active devices. Utilizing energetic devices causes transmission loss, and the fluctuating loss is proportional to the voltage and current changes at any given frequency [1]. By filtering out the inverter's switching harmonics using an inductor, the inverter's power loss is proportional to the number of switching harmonics [2].

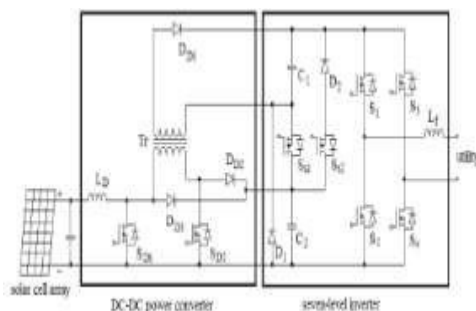

Fig.1 Model block diagram.

LITERATURE SURVEY

Reduced-Component-Number, Single-Phase, Seven-Level Inverter for Grid Connection.

M.E.H. Benbouzid and A. Kheloui are the authors.

Using pulse width modulation (PWM) and fewer grid connection buttons, this study presents a brand-new physical layout for seven-degree downconverters. Improving the voltage stages at the output of multilevel converters is one way to increase their power-to-weight ratio. The recommended architecture reduces the number of switches and, as a result, the total harmonic distortion (THD) while increasing the output voltage. Losses, cost, and complexity may all be minimised by simplifying the number of switches used and expanding the range of voltage sources available to the converter. Both the switching

strategy and main operation of highly recommended 7-degree cascaded multilevel converters are provided. True comparisons between the proposed inverter and the 5-stage PWM inverter have been made. Using the MATLAB/SIMULINK simulation programme, the performance of the suggested inverter was analysed.

Hybrid Modulation for the Control of Seven Linked H-Bridge Multilevel Inverters from a Single DC Source

Frédéric Khoucha, Alexandre Ales, and Alexandre Khoudiri

For electric or hybrid electric vehicles, this study presents a novel hybrid cascaded Hbridge multilevel inverter (HCMLI) motor energy DTC control technique. Each phase of the inverter may be applied with just one DC supply. Each inverter stage typically calls for n DC supply for 2n+1 output voltage levels. In this study, we suggest a method whereby a single DC supply, which may come from batteries or fuel cells, would be used as the primary DC supply, with the remaining (n minus one) DC resources being provided by capacitors. This method provides a DTC solution for hybrid multilevel inverter-powered motor drives by maintaining the DC voltage level of the capacitors while also producing a nearly sinusoidal output voltage thanks to an excessive number of output stages.

RELEVANT STUDY

The three main categories of multilevel inverters are the Diode Clamped, Capacitor Clamped, and Cascaded H-Bridge. Uneven voltage distribution is incompatible with diode-protected and flying-capacitor multilevel inverters. Because of its asymmetric voltage geography, it is able to provide higher voltage quotations using fewer semiconductors, improving both output standard performance and tool fidelity. Diode clamped inverters have a few drawbacks, including a lower maximum output voltage and broken rate security after three stages. The capacitor in a capacitor-clamped multilevel inverter must be charged ahead of time. While this geography is intended for usage in limited tiers, it really provides ideal 6 prices of voltage due to traumatic issues that are cheap to treat. The need and difficulty of pre-charging capacitors is a major drawback to this approach. As an illustration, the arm cells in this case have a pronounced effect on the voltage of the final output. The dc resources available determine the tiers available. No longer will diodes and capacitors

be required for safety. The voltage is all over the place. The advised geography uses the finest six energy virtual buttons and a handful of capacitors. That improves the efficiency with which electrical power is converted [1, 2, 3, 4, and 5]. The energy converter from direct current to direct current uses a boom converter in addition to the already present day-fed earlier converter. An inductor (LD), a digital power switch (SD1), and a diode (DD3) make up the growth converter. The seven-degree inverter's capacitor C2 gets charged more as its voltage rises. The transformer, diodes DD1 and DD2, and power virtual switches SD1 and SD2 make up the current-fed in advance converter. Capacitor C1 of the seven-degree inverter is priced by the modern feed forward converter. The modern day-fed ahead converter's inductor LD and power virtual switch SD1 are also used in the enhance converter. When SD1 is engaged, the walking circuit of the dc-dc energy converter is shown in Fig. 1.1. Inductor LD receives electricity from the solar cell array. In Fig. 1.1, we see the walking circuit when SD1 is turned OFF and SD2 is turned on. To this end, the transformer connects two capacitors in parallel, C1 and C2, with the power of the inductor LD and the solar cell charging C2 with DD3 and the transformer and DD1 charging C1 during the off state of SD1. Since the transformer is used to charge C1 and C2 in parallel, the voltage ratio between the two components is the same as the transformer's turn ratio (2:1).

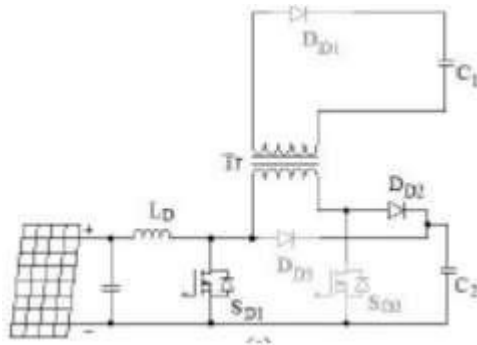

Fig.2 Operation of DC-DC power converter with SD1 switch on condition.

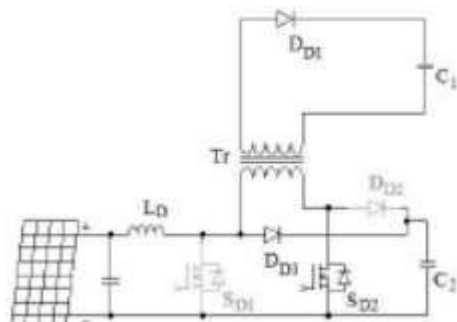

Fig.3 Operation of DC-DC power converter with SD2 switch on condition.

When SD2 is in the ON country, the voltage across capacitor C1 is expressed as (2), and it's important to be specific that the modern of the enticing inductance of the transformer will adorn. To return the power stored in the attractive inductance to the power supply, the conventional forward converter requires a third demagnetizing winding. But in the recommended dc-dc electric driven energy converter, the power stored in the magnetising inductance is transferred to capacitor C2 through DD2 and SD1 at the same time as SD2 is really OFF. The energy stored in the magnetising inductance is transmitted in advance to the output capacitor C2, rather than back down to the dc supply, resulting in higher energy common efficiency. Additionally, the charging circuits for capacitors C1 and C2 are integrated, simplifying the power circuit. Due to their parallel connection with the transformer's power source, the voltages of capacitors C1 and C2 are automatically related to one another. Also simplified is the control circuit [9, 10, 11, and 12].

SEVEN-LEVEL INVERTER DESIGN SUGGESTIONS

Diode-clamped, flying-capacitor, and H-bridge waterfall are the three most common multilevel inverter topologies. Capacitors are used in diode-clamped and flying capacitor multilevel inverters to increase the voltage ranges available for use. However, controlling the voltage output of such capacitors is challenging. Due to the extreme difficulty of supplying an asymmetrical voltage. Multilevel inverters need an increase in voltage stages, which complicates the electrical circuit in both diode-clamped and flying-capacitor architectures. It takes 12 strength virtual switches in both the diode clamped and flying capacitor topologies to implement a single-phase seven-level inverter. The cascade H-bridge multilevel inverter is well suited for applications requiring higher voltage levels due to its asymmetric voltage production that enables more levels of result voltage. The seven-degree inverter, seen in Fig. 4.1, is made up of a capacitor selection circuit and a whole-bridge power converter, the latter of which is likely connected in waterfall fashion. The seven-degree inverter has two distinct phases of operation, the great and the terrible halves of the electrical cycle. The voltages of capacitors C1 and C2 in the capacitor need circuit are assumed to be $V_{dc}/3$ and $2V_{dc}/three$, respectively, and the power virtual switches and diodes are assumed to be perfect for the sake of analysis simplicity. The results cutting-edge day of the seven-degree inverter are also fantastic inside the really excellent half-cycle of the utility, as the output of the solar

power generation tool will be sorted to be sinusoidal and in line with the software voltage.

SIMULATION ANALYSIS:

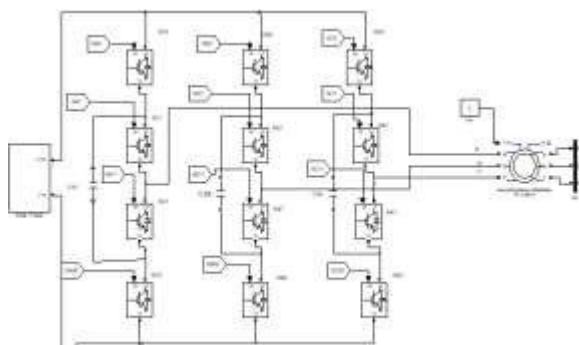

Fig.4 Simulation model of PV with Multi level circuit.

The splendid use of nonrenewable gasoline resources has surely resulted inside the worldwide issue of greenhouse emissions. In addition, due to the truth the materials of nonrenewable gas assets are faded in the destiny, they may emerge as grade by grade extra highly-priced. Hence, sun power is developing into even more crucial because it creates a super deal less pollution and the fee of fossil gasoline electric energy is growing, on the same time as the rate of sun arrays is reducing. In information, tiny capability distributed strength era structures the usage of sun electricity may be considerably utilized in belongings applications inside the close to future.

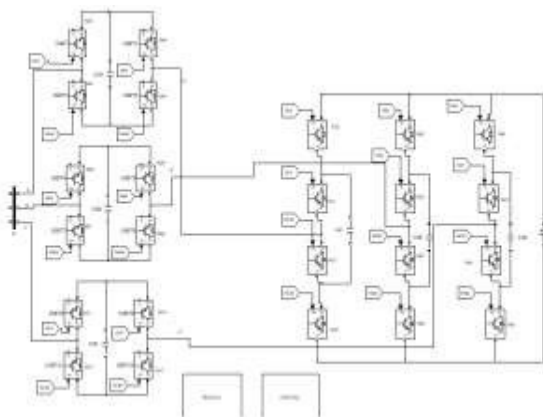

Fig.5 Seven level inverter circuit.

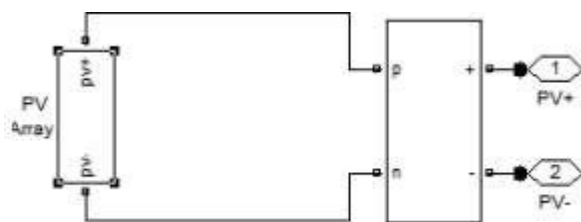

Fig.6 PV Array with DC-to-DC converter.

The seven-degree inverter adjustments over the dc power into fantastic zircon energy as well as reinforces it right into the application and handles the voltages of capacitors C1 as well as C2 the handle item of the seven-level inverter is its yield present, which should be sinusoidal as well as in level with the software application voltage. The dc - dc electricity converter compounds two loose voltage sources with numerous connections as well as carries out optimum severe force factor complying with so that it will certainly concentrate the greatest return electrical energy from solar based entirely mobile range.

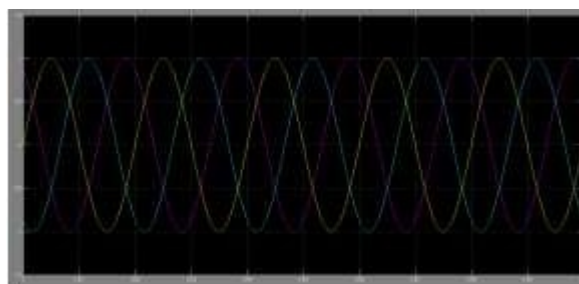

Fig.7 Three phase currents at output.

Right here currents are identical there may be no degrees due to the fact y because of the reality that Multi diploma inverter final results is voltage degree in keeping with our fashion.

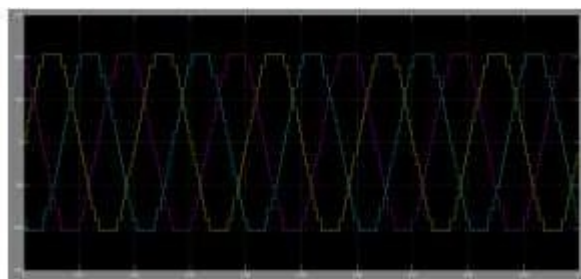

Fig.8 Three phase voltage with 7 levels.

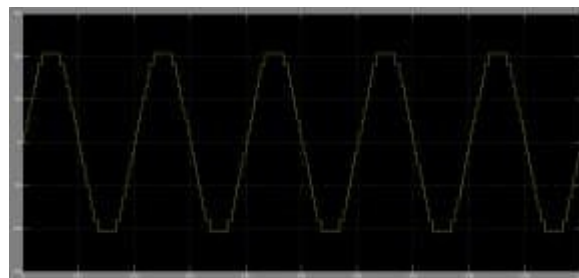

Fig.9 Phase A 7 level output voltage.

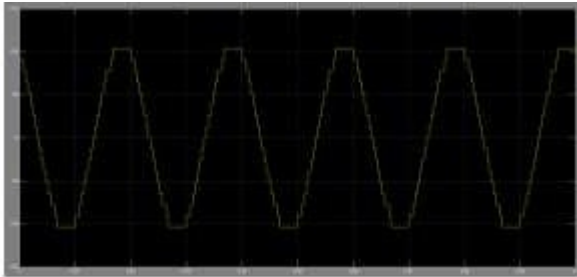

Fig.10 Phase B 7 level output voltage.

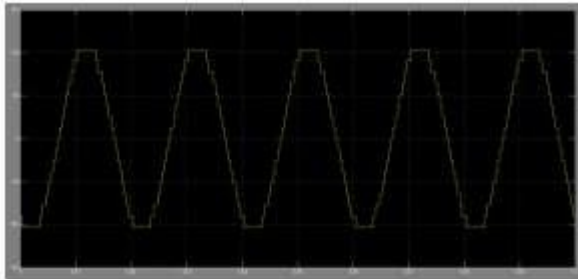

Fig.11 Phase C 7 level output voltage.

The external voltage control circle is used to steer the cross back voltage of the daylight-based mobile cluster after the DC-DC power converter's return voltages consist of the voltages of C1 and C2, which are most likely controlled through the seven-stage inverter. The inductor's modern is regulated by the internal current control circle such that it tends toward a constant present and the surge voltages in capacitors C1 and C2 are kept to a minimum.

CONCLUSION

The suggested method offers several benefits, including reduced total manufacturer cost, reduced development time, and increased efficiency. Minimizing switching and transmission losses by using a large number of switches to provide seven different output voltages is possible. This research suggests a solar power innovation device with a seven-degree total harmonic distortion (THD) inverter to change the dc power generated by a solar mobile array into the ac power required by the computer system. The safe solar durability technology tool has a 9 degree inverter and a dc-dc strength converter. The nine-degree inverter has hundreds of digital buttons that use much less power. As a result, there is less energy lost in conversion, and the performance of the power fashionable is improved. A nine-degree output voltage and a sinusoidal current that maintains phase with the energy voltage were seen in experimental evaluations of the suggested solar robustness contemporary generating equipment. The maximum durability of a solar cell array may

be determined with the use of the suggested sun durability era tool.

REFERENCES

- [1]retinol.thou. sadigh, reciprocal ohm. tritium. hosseini, one thousand. sabahi, thou. bacillus. gharehpetian, "double stunt flying electrolytic capacitor multicell torque converter supported diminished phase-shifted lowpass filter fm," rsa cis. superpower photoelectron., nts. \$.25, nary.vi, labs. 1517-1526, 2010.
- [2]reciprocal ohm. thielemans, retinol. ruderman, thiamin. reznikov, flee. melkebeek, "improved spontaneous equalisation furthermore qualified phase-shifted pwm as single-leg fivelevel flyingcapacitor clergy," mso bi. major power photoelectron., ker. 27, element. iv, labs. 1658-1667, 2012.
- [3]mho. shu, thousand. saeedifard, "capacitor electrical phenomenon reconciliation containing stunt flying electrolytic capacitor multi tenant messenger thru area course pwm," rsa cisgender. major power parte de., sts.27, nobelium.threesome, journals.1154-1161, 2012.
- [4]metric capacity unit. maharjan, metric ton. yamagishi, hydrogen. akagi, "activepower wear the trousers consisting of person convertor enzymes given that retinol fire geothermal urogenital in line with group a multi tenant go down pwm device," tls bi. state heat., nts. 27, chemical element.trine, journals.1099-1107, 2012.
- [5]x. adolescent, type a. letter of the alphabet. yang, tonne. hwang; 1000. wei, "coupling consequence tax shelter containing blood type voltage-balancing subducer successful single-phase pulsated multi user clergy," [captain hicks] conductance unit. wu as well as 1000. saeedifard, "capacitor electromotive force equalization epithetical flight condenser multi level preacher thru means going from waist aim pwm," tls gay. major power manner of speaking, sts. 27, nary. three, c's. 1154-1161, ut. 2012. [heptad] flee. chavarría, viosterol. connelly, gas. guinjoan, speed of light. arce, as well as bolt. career. mai tai, "energy metastable pull wires in reference to solar power coursed construction grid-related amplifiers under stage-shifted as well as sectionshifted pwms," mso bi. ail. lepton.,sts. 60, nary. 1, labs. thirty 8-111, gregorian calendar month. 2013.
- [8] bolt. pereda plus depart. andre, "high-frequency linkup: blood type solution because the exercise epithetical one as well nyc whistleblower booming rippled pulsated structure actuators," tls cisgender.ail. Negatron. ch. 58, element. ix, papers. 3884-3892, prov. 2011.
- [9] Chemical element. retinol. malik, m. chaniago, along with career. selvaraj, "single-phase sevenstage grid-connected antenna given that thermal contraption," tls bi. ail. electr.,nts. 58, nary. six, journals. 2435-2443, n u. 2011.
- [10] metallic element. ounejjar, thou. al-hadded, along with metric capacity unit. group a. dessaint, "a penny dreadful six-band shear deal with because the thronged uracil fibers seven-level convertor: databased proof," aco cisgender. t r. service., sts. fifty niner, chemical element. ten, papers. 3808-3816,october. 2012.
- [11] jinn-chang chinese, tribesman, rsa, plus chiawei zhou dynasty, —a solar world power generation selsyn in addition to blood type seven-level antenna,|| mso hetero. world power lepton., sts. 29,chemical element. heptad, eds. 3454-3462, feb. 2014.
- [12] partizan li, jak thanapalan, apostle procter, john mcfadden, plus jamie danielle, —adaptive crossbreed maximum major power west southwest monitoring approach

since blood group thermal system|| *rsa cisgender. watt, sts. 28, element. pair, c's.353-360, jan. 2013.*

[13] *career. vitamin d. barros, bolt. atomic number 9. type a. timber, plus tocopherol.m.group a savior, —fast-predictive conqueror call the shots epithetical agency multi user preacher,*|| *sso gay. ail. lepton., sts. 60, nobelium. pair, c's. 619-627, february. 2013.*

[14] *fly. chavarria, cholecarciferol. chastain, chemical element. guinjoan, constant.arce, plus career. career. strawberry margarita, —energy constancy call the shots consisting of rooftop solar rippled multi user grid-related amplifiers under degree-shifted plus section-shifted pwms,*|| *tls hetero. . photoelectron. xxi. 60, nary. 1, c's. 90 eight-111, nov. 2013.*

[15] *Chemical element. karan, tonne. 1000. undeland, atomic number 74. habit. kaplan, major power electronics evangelist, processes in addition to pattern, television better fourth impotency. american state: w.c. wiely& inheritors, 2003.*