



**IJITCE**

**ISSN 2347- 3657**

# International Journal of Information Technology & Computer Engineering

[www.ijitce.com](http://www.ijitce.com)



**Email : [ijitce.editor@gmail.com](mailto:ijitce.editor@gmail.com) or [editor@ijitce.com](mailto:editor@ijitce.com)**

# AUTONOMOUS ROBOTS GUIDANCE WITH VOICE COMMAND SYSTEM

K.KOTESWARA RAO<sup>1</sup>, G.KALYANA CHAKRAVARTHI<sup>2</sup>, E.NAVYA SREE<sup>3</sup>

**Abstract**— The basic key to fresh innovation is now in the hands of robotics. Human-to-human contact is becoming more commonplace, and individuals are taking advantage of it. Everyone has accepted physical tactics instead of rational ones. Robots may be tracked using a security system based on Bluetooth. The user may now operate the robot using IOT technologies after completing registration. Predefined buttons on the webpage may be used to operate the robot. If an obstruction is encountered either in front of or behind the robot, it will come to a halt. With a microcontroller and speech recognition software, a limited number of vocal patterns may be recognised by the suggested proposed system.

**Keywords:** Voice Command, Autonomous Robot.

## INTRODUCTION

An intriguing project might be included into the regular curriculum, according to certain teaching methods Students' retention and comprehension of material are proven to be improved when projects are included in lectures. Some of these endeavours aim to create intelligent systems. Students have wanted to build intelligent robots or intelligent systems since since they first saw humanoid robots in science fiction movies. As a result, students' interest in microprocessors may be piqued by the use of intelligent robots or intelligent systems. Autonomous mobile robot with a computer-controlled tiny mouse that can navigate its way around a labyrinth. The

competition for the tiniest mouse has received great scores for both exposure and innovation. However, the micro mouse competition must be held in a labyrinth with an arbitrary set of rules. A vision-guided autonomous vehicle is presented as an alternative to the micro mouse competition since most testing of the micro mouse needs a labyrinth and students cannot test their cars at home. The track of a vision-guided autonomous vehicle may simply be made. It's possible to tailor the degree of difficulty on software to meet the student's needs. Since a computer is used to analyse the images as well as drive the vehicle, vision-guided autonomous driving is possible.

123Associate Professor, Dept. of CSE, R.K.College of Engineering, A.P., India.  
e-mail:kkotesh@yahoo.com

Computer vision, artificial intelligence, and fuzzy logic courses are more suited for the vehicle project than microprocessor courses. Intelligent autonomous robots engage in a soccer match as part of the MIROSOT (Micro-Robot World Cup Soccer Tournament). In this game, the host computer interprets visual data and determines the locations of the ball and robots. Through RF connection, each robot gets this location information from the host computer. Each robot makes its own decisions on how to play soccer based on the data collected by its sensors and visual system. Sensor fusion, intelligent control and robotics, communication, image processing, mechatronics and computer technology are just few of the fields where individuals from diverse backgrounds are working together to produce intelligent soccer robots. At the interface level, a strong speech recognition method should be employed to ensure that commands are properly acknowledged and/or identify the circumstances in which they are being given. The Human-Robot interface was implemented on an Android smartphone in the project detailed here. An Arduino board was used to operate the robot. Bluetooth was used to connect the Android handset to the Arduino board. The robot utilised was a Kobuki, which had three bumpers on the front and two powered wheels. Any impact coming from the direction the bumpers are set in will be detected by the system. In front of the Arduino, There is a pre-programmed set of fundamental activities. After receiving a command, the robot begins the required series of steps to carry out that instruction and its particular motion. It is a computer system intended to accomplish a specific task, sometimes with real-time computing limitations, contained in a more general system. Part of a larger device, frequently incorporating hardware and mechanical components, it is integrated General purpose computers, such as a personal computer (PC), are intended to be versatile and to fulfil the demands of a broad variety of users. In today's society, embedded systems are used to operate a wide range of gadgets.

Microcontrollers and digital signal processors are the most common types of central processing units used in embedded systems (DSP). Being able to tackle a certain job, which may demand strong processors, is the most important attribute. Air traffic control systems, for example, are advantageously considered as embedded, despite the fact that they require mainframe computers and specialised regional and national networks connecting airports. Embedded systems are likely to be included in each radar. It is possible to lower the size and cost of a product by optimising the embedded system since it is devoted to a certain activity. For example, certain embedded systems benefit from economies of scale since they are mass manufactured. Digital watches and MP3 players are examples of portable embedded systems. for big fixed installations such as traffic lights, industrial controls, or nuclear power plant systems. The level of complexity ranges from a single microcontroller chip to a huge chassis or enclosure with many units, peripherals, and networks.

#### **EXISTING TECHNIQUE**

Voice recognition-controlled circuitry in action The HM 2007 speech recognition processor and a static RAM are used to build a voice recognition circuit (IS62c64AN). Keypad and microphone are included in the additional circuitry. It has a single speech recognition chip, HM 2007, which has a 3.58 MHz CPU and an antilog front end, an ADC, and an automatic gain control (AGC). The HM 2007 includes a 13-bit address bus, an 8-bit data bus, and control pins that convey memory enable and memory read/write signals to connect with external memory. A voice input readiness indication is provided by the chip. This pin is linked to the indicator. power supply via a LED in It's here. Predefined in [6] are three error codes 55 (word length is too long), 65 (word length is too short), and 77 (word is not a match). An 8-bit binary coded decimal (BCD) nibble is not generated by the speech recognition circuit, but rather two 4-bit binary coded decimal (BCD) nibbles. When the battery is linked to a positive voltage regulator (LM7805), the circuit's voltage

is stabilised at 5 volts. SRAM is also given a second backup supply of power of +3 volts from this controlled +5 volt supply a battery with a voltage of (Lithium cell). Even if the main power is turned off, the SRAM chip's backup battery keeps all of its memory intact. That means there's no re-training required once the main power is off. As soon as the circuit is switched on, the HM 2007 will do an SRAM check. Upon successful completion of the verification procedure, the recognition unit will show "00.". The processor's readiness indication pin will generate a low signal, which will cause the green LED to illuminate. If the chip is in this stage, it's ready to go through further processing. The voice recognition controlled circuit must be trained. B. To begin, we need to punch a pair of any word numbers between 01 and 99, save for 55, 66, and 77, on the keypad to activate the circuit. After pushing two digits, the LED will turn off, signalling that it is now ready for the training procedure. In order to begin training a command word, we must first push the "TRN" button (#). In order to turn the LED back on, click the "TRN" button (#). Once in this position, the chip is prepared to learn a new word. As a result, we'll need to say a command word into the microphone. When the word is approved, the LED will turn off for a

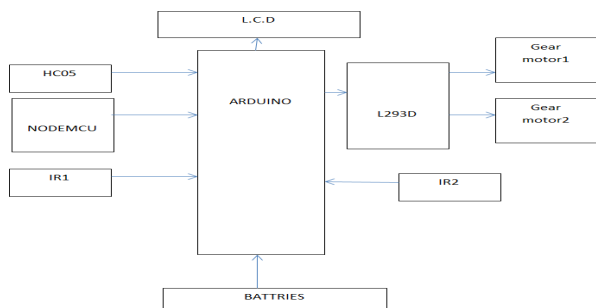

brief period of time. Afterwards, the LED will continue to light up. This process may be used again and again to train additional words in the recognition unit after a command word has been successfully trained.

Cons of Current Methods: • The robot can be controlled by anybody who knows how to access the internet.

• On the robot's end, there's no official password.

- A greater need for electricity.
- Reduced dependability

### PROPOSED TECHNIQUE

Robots can be controlled and communicated with using speech. As we'll see, the voice recognition circuit works independently of the robot's primary brain [its central processing unit (CPU)]. Good news, since word recognition does not require any of the robot's CPU processing resources. To see whether the robot has received a command, the CPU just has to periodically query the voice circuit's recognition lines. The identification line may be connected to one of the robot's CPU interrupt lines, which will allow us to optimise the system even more. An interrupt would be generated, informing the CPU that a recognised word had been uttered, as a result. Using an interrupt eliminates the need to periodically poll the circuit's recognition line, resulting in reduced CPU overhead. Programmability is another benefit of this stand-alone speech recognition circuit (SRC). The SRC may be programmed and trained to identify certain words. Using the SRC, the robot's CPU may be readily connected to it. To have command and control over a machine (computer, VCR, TV security system, etc.) by speaking to it, will make it easier, while increasing the efficiency

and the efficiency with which you can operate with it. Using voice recognition as a fundamental tool, a person may multitask with the computer or other device while their hands and eyes are occupied with other things. The field of robotics is constantly growing. No one can predict which technique or technology will be utilised to manufacture robots in 100 years time. Darwinian evolution is taking place in robotics, just as it does in biology.

In order to start the robot securely, the HC-05 Bluetooth module is used.

A wifi module allows the robot to be steered in any direction using IOT technology.

- If an obstruction is in front or behind the robot, the robot will come to a halt.

## **VOICE COMMAND FOR AUTONOMOUS ROBOTS**

A wide range of industrial sectors rely heavily on robots. Reason being that operating a robot costs a fraction of what human labour does per hour. The same thing. In addition, once a robot has been trained, it is able to do the same task again and over again with the same level of precision as the most experienced human operator. Human operators, on the other hand, are far more adaptable. Humans have the ability to effortlessly swap jobs. It is common practise to design and programme robots to do just a specified set of tasks. In order to count the components in a bin using a welding robot, you would need to write an additional software. The most sophisticated industrial robots of today will eventually be referred to as "dinosaurs." The development of robots is still in its infancy. Eventually, robots will be able to do a variety of activities at once, much like humans. The personal robot has yet to make an appearance, but the personal computer has left a lasting impression on society. A personal robot is obviously more than just a personal computer. For robots to be successful, they need a mix of attributes: intellect, movement, mobility, navigation, and a sense of mission. Voice recognition is based on identifying the unique characteristics of each speaker's voice. Speech patterns differ from person to person because of differences in anatomical features (such as the size and shape of the mouth and throat) and psychological traits (such as the pitch of one's voice, the way one speaks, one's accent, etc.). It's clear that speech and voice recognition are two distinct technologies. A speaker's identity or that of an unknown speaker are the most typical uses of voice recognition technology. Common methods of verifying and identifying speakers include speaker verification and recognition of a voice. The created system's correctness is checked once it has been developed. Many command words have been sent into the system to fine-tune it. Each command word has a unique word number associated with it. The words "number" and "command word" that have been taught

are shown in Table 1. A quiet room is used for the testing, and a natural setting outside the room is used for the outdoor testing (noisy area). In Fig.7, you can see the circuit's response accuracy. A total of 20 sets of trials were conducted for each of the command words. The graph shows that in a quiet environment, the speech recognition circuit's accuracy is 99 percent, but in a loud one, it is At least 95%. As a result, assigning instructions in a loud environment reduces the accuracy of the speech recognition circuit. Furthermore, the two identical command phrases "forward" and "reverse" can cause the system to malfunction. It's a "ward" term because of the similarities between these two nouns. As a result, the instruction to switch off one device may unintentionally turn off another.

## **CONCLUSION**

A speech recognition processor, a microprocessor, and other low-cost components are included in this paper's suggested system, which undergraduate students may simply design and build. All voice commands must be recognised in order for a single voice recognition processor to identify more than the maximum number of Grouped instructions are structured such that the speech recognition engine always attempts to discover the most comparable vocal pattern from one memory unit. Speech commands cannot exceed the maximum number of recognitions that may be made by a single voice recognition processor. Different from prior contests, a number of fascinating ones might be held under the suggested approach in order to further inspire pupils. As the educational environment changes, so may the suggested voice command system and its many uses beyond autonomous robots.

## **REFERENCES**

- [1] The IEEE Transactions on Education, vol. 31, no. 3, August 1988, pp. 172-176, C. E. Strangio, "Microprocessor teaching in the engineering laboratory."
- [2] An advanced microprocessor interface laboratory is described in the IEEE Transactions

on Education, Vol 32, No 2, pages 124-128 in May, 1989 by B. Furht and PS Liu.

[3] In "A laboratory for microcomputer instruction at diverse levels," IEEE Transactions on Education, vol. 35, no. 3, Aug. 1992, pp. 199-203. [3]

In "Control Device Effects on Telerobotics Manipulation Operations," by J. M. O'Hara and R. E. Olsen, Robotics and Autonomous Systems Vol. 4, No. 4, 1988.

[4] According to the IEEE Transactions on Education: "Integration of micromouse project with undergraduate curriculum: a large-scale student engagement method."

[5] An alternate micromouse competition: "A Vision-Guided Autonomous Vehicle," IEEE Transactions on Education, May 1997, pp. 253-258; [7] N. Chen

[6] "Collision avoidance among multiple autonomous mobile robots using LOCISS," in Proceedings of the 1996 IEEE International Conference on Robotics and Automation, Minneapolis, Minnesota, pp. 2091-2096.

[7] "Multimodal Error Correction for Speech User Interfaces," ACM Transactions on Computer-Human Interaction, Vol. 8, No. 1, pp. 60-98, 2001.

[8] Micro-Robot World Cup Soccer Tournament Proceedings, Taejon, Korea, Nov. 1996, pp. 11-16