



**IJITCE**

**ISSN 2347- 3657**

# International Journal of Information Technology & Computer Engineering

[www.ijitce.com](http://www.ijitce.com)



Email : [ijitce.editor@gmail.com](mailto:ijitce.editor@gmail.com) or [editor@ijitce.com](mailto:editor@ijitce.com)

## HEAVY WEIGHT LIFT MACHINES DESIGN

<sup>1</sup>Dr. NAGA SIVA PRASAD  
<sup>2</sup>RAVINDRANATH TAGORE K  
<sup>3</sup>P NAVEEN REDDY  
<sup>4</sup>R HARI KRISHNA

---

### ABSTRACT;

Efforts to generate any form of work have been steadily reducing as technology has advanced. Implementing improved designs may reduce the amount of work necessary to get the intended result in an efficient and cost-effective manner. A human cannot lift weights over a specific limit; in these instances, a jack is required. It gets easier to use when it is powered by a motor. In order to put this concept into action, we created a motorised jack switch system that allows us to simply raise and lower the jack using the on/off switch. Worker strain is reduced by this. The motorised screw jack was developed primarily to alleviate the strain placed on humans when hoisting loads. The project is more cost-effective and efficient to run than other alternatives. mechanical device used to raise huge weights and exert considerable force jacks, screwjacks, and jackscrews Screw thread lifts heavy machinery using a mechanical jack. Hydraulic power is used to operate a hydraulic jack. Lifting automobiles to do maintenance is a frequent use for a variety of jacks, the most common of which being car, floor, and garage jacks. It is common for jacks to be evaluated for their lifting capabilities (for example, 1.5 tonnes or 3 tons). There are industrial jacks that can handle loads of numerous tonnes. In this article, we'll look at how to build a tiny hydraulic jack that moves vertically using hydraulic force. The hydraulic jack in our system is cleverly developed and capable of lifting huge weights despite its small size. The device comprises of a lightweight yet sturdy lifting jack mechanism. A syringe is used to power this device, which is designed to raise the maximum weight for its size. With this device, you'll find a bed on top of the mechanism where you may lay the automobile or weight you want hoisted.

---

### INTRODUCTION

An automotive jack is a device used to raise all or part of a vehicle into the air in order to facilitate vehicle maintenances or breakdown repairs. The use of jack is not new. It has developed to its present sophisticated state over many years. There are two main types of automotive jacks: Hydraulic and screw jacks. These two categories also have many subcategories of jacks. A screw jack is a type of jack which is operated by turning a lead screw. In this jack, a small force applied in the horizontal plane is used to raise or lower large load [1, 2]. Of the screw-type mechanisms, there are scissor jacks, common in newer cars, and bumper jacks, common in older cars [3, 4]. Hydraulic jacks have the shape of

a bottle, or built into a trolley (the floor jack), friction jack and racking jack [1]. The hydraulic jack has all the advantages of producing tons of closer controlled torque-free power for minimum effort by the operator. The hydraulic jack is ideally suitable for repair work because it could be operated in any plane and controlled from outside the car. A large percentage of work will require the use of hydraulic jack for lifting, pulling, pushing and alignment. It is not only used in automobile industries for repairs but warehousing establishments, storage establishments, distributors, service stations and couriers also use hydraulic jacks for a range of high pressure and

---

Department of Mechanical Engineering, Nagore University Engineering and Technology Hyderabad

heavy-duty lifting procedures. The device itself is light, compact and portable, but is capable of exerting great force [5, 7]. Hydraulics is the science of transmitting force or motion through the medium of a confined liquid. In a hydraulic device, power is transmitted by pushing on a confined liquid. The transfer of energy takes place because a quantity of liquid is subject to pressure [8]. The device pushes

pistons. Therefore, the small piston must be moved a large distance to get the large piston to move significantly. The distance the large piston will move is the distance that the small piston is moved divided by the ratio of the areas of the heads of the pistons. This is how energy, in the form of work in this case is conserved and the law of conservation of energy is satisfied in the hydraulic jack. Work is force times distance, and since the force is increased on the larger piston, the distance the force is applied over must be decreased [9, 10]. A hydraulic jack uses a liquid, which is incompressible, that is forced into a cylinder by a pump plunger. Oil is used since it is self-lubricating and stable. When the plunger pulls back, it draws oil out of the reservoir through a suction check valve into the pump chamber. When the plunger moves forward, it pushes the oil through a discharge check valve into the cylinder. The suction valve ball is within the chamber and opens with each draw of the plunger. The discharge valve ball is outside the chamber and opens when the oil is pushed into the cylinder. At this point the suction ball within the chamber is forced shut and oil pressure builds in the cylinder. Although the hydraulic jack has all the above advantages, it has one major problem of an unexpected hydraulic failure. This, therefore, needs further research in order to overcome such a problem. On average, 160 injuries are associated with car jacks each year. Injuries have ranged from amputation to fractures and crush injuries. Improvement and the correct use of jacks can prevent death or injury. Improvement in automotive car jack is really needed to make the tool more efficient, user-friendly, practical to use, changes in industry direction and

liquid against a piston; pressure is built in the jack's container. This is based on Pascal's law which states that the pressure of a liquid in a container is the same at all points.

Pressure on a confined liquid is transmitted undiminished and acts with equal force on equal areas and at 90 degrees to the container wall. A liquid, such as oil, is displaced when either piston is pushed inward. The small piston, for a given distance of movement, displaces a smaller amount of volume than the large piston, which is proportional to the ratio of areas of the heads of the

most importantly high safety features [11, 12]. The modification of small hydraulic jack is intended to be of value to the automobile industries, private and especially the commercial vehicle users. The mechanism added will support the existing jack after it has lifted the load so that it will act as an additional support to strengthen the effort of the jack even when there is failure. More specifically when moving along the road and a punctured tire or a tire is to be changed, it will serve as an axle stand and a jack at the same time i.e. it will have multi-purpose function of lifting and acting as a supporting unit. In addition, to ensure the safety of the hydraulic jack during unexpected hydraulic failure the improved mechanism will act as a locking stand.

As per Pascal's law, the above intensity  $p$  will be equally transmitted in all directions. Therefore, the pressure intensity on ram Above equation indicates that by applying a small force  $F$  on the plunger, a large force  $W$  may be developed by the ram. Mechanical advantage of jack If the force in the plunger is applied by a lever which has a mechanical advantage then the total mechanical advantage of jack. The ratio is known as

$$P = F/a = W/A \text{ OR } W = F(A/a)$$

### 1.1 Types of Screw Jack

Jacks are of mainly two types- mechanical and hydraulic. They vary in size depending on the load that they are used to lift. (a) Mechanical Jacks: A mechanical jack is a device which lifts heavy equipment. The most common form is a car jack, floor jack or garage jack which lifts vehicles so that

maintenance can be performed. Car jacks usually use mechanical advantage to allow a human to lift a vehicle by manual force alone. More powerful jacks use hydraulic power to provide more lift over greater distances. Mechanical jacks are usually rated for maximum lifting capacity. (b) Hydraulic Jacks: Hydraulic jacks are typically used for shop work, rather than as an emergency jack to be carried with the vehicle. Use of jacks not designed for a specific vehicle requires more than the usual care in selecting ground conditions, the jacking point on the vehicle, and to ensure stability when the jack is extended. Hydraulic jacks are often used to lift elevators in low and medium rise buildings. A hydraulic jack uses a fluid, which is incompressible, that is forced into a cylinder by a pump plunger. Oil is used since it is self lubricating and stable. When the plunger pulls back, it draws oil out of the reservoir through a suction check valve into the pump. When the plunger moves forward, it pushes the oil through a discharge check valve into the cylinder. The suction valve ball is within the chamber and opens with each draw of the plunger. The discharge valve ball is outside the chamber and opens when the oil is pushed into the cylinder. At this point the suction ball within the chamber is forced shut and oil pressure builds in the cylinder.

## 2. LITERATURE SURVEY

Giuseppe et al. [1], describes the motorized wheelchairs dates back in time with several scientists and researcher evaluating the stair climbing mechanism. This paper evaluates different stair climbing mechanisms viz crawler type, leg type, hybrid type and wheeled type. Various forces and torques acting on the wheelchair while climbing the stairs are evaluated. Preferably the outer support assembly comprises wheels on either side of the chair. An inner support assembly, closer to the center line of the chair, also supports the seat assembly. Murray and Takakazu [2], the rear wheels are autonomously driven and front wheels are freewheeling castors. This proposed concept is numerically modeled and power calculations for linear actuator are made. Stair ascent and stair descent operations are described along with figures and equations. The control system and the stair edge sensor system are also investigated. The stepping algorithm is discussed in detail. The influence of external factors like cost, weight, aesthetics, range of

operation, safety, operational efficiency, comfort is evaluated.

Simpson et al. [3], presented that, the stairs will most likely always be a reality in the real world, because of the high level of spatial efficiency they provide when connecting areas of differing vertical elevations. Stairs do present an increased degree of danger compared to such as gentle slopes but this must to some degree by necessity be simply considered. For example, in the planning of any new buildings the target users should be considered. Clearly for public amenities, such as wheelchair users should be considered, but for example in the case of say a private home in Japan where land space is at a premium (more specifically very expensive) multilevel construction is unavoidable and stairs will most likely continue to be used. A compromise situation in the case of families caring for aging parents is often providing all the essential amenities at ground level (barrier free) and using the upper levels for the younger families' respective bedrooms etc.

Morales R et al. [4], describes the mechanical devices, the movements and the trajectory generation of a novel wheelchair prototype capable of climbing staircases. The key features of the design are the use of two decoupled mechanisms for each axle, one used to negotiate steps, and the other position the axle with respect to the chair to accommodate the overall slope. This decoupling makes many different climbing strategies possible, the overall mechanism becoming extraordinarily versatile from a control point of view. A control system is necessary to synchronize the movements of all the actuators of the wheelchair so that its center of mass can follow arbitrary spatial trajectories.

## 3. PARTS DESCRIPTION

Geared dc motor

- Battery
- Pen Description
- Power Supply
- Controller
- Transformer
- Microcontroller

### 3.1 GEARED DC MOTOR

The electrical motor is an instrument, which converts electrical energy into mechanical energy. According to Faraday's law of Electromagnetic induction, when a current-carrying conductor is placed in a magnetic field, it experiences a mechanical force whose direction is given by Fleming's left-hand rule. Constructionally, a dc generator and a dc motor are identical. The same dc machine can be used as a generator or as a motor. When a generator is in operation, it is driven mechanically and develops a voltage. The voltage is capable of sending current through the load resistance. While motor action, a torque is developed. The torque can produce mechanical rotation. Motors are classified as series wound, shunt wound motors



Fig3.1:DC Motor

#### 1.3.5 Spur gears

These are designed to transmit motion and power between parallel shafts which are the most economical gears in the power transmission industry. Two types are used in this model:

##### 1.3.5.1. Internal spur gear

These spur gears are turned inside out. In other words, the teeth are cut into the inside diameter while the outside diameter is kept smooth. This design allows for the driving pinion to rotate internal to the gear, which, in turn, allows for clean operation. Intended for light-duty applications, these are gears always available only in brass. When choosing a mating spur gear, always remember that the difference in the number of teeth between the internal gear and pinion should not be less than 12 or 15.

##### 1.3.5.2 External spur gear

Perhaps the most often used and simplest gear system, external spur gears are cylindrical gears with

straight teeth parallel to the axis. They are used to transmit rotary motion between parallel shafts and the shafts that rotate in opposite directions. They tend to be noisy at high speeds as the two gear surfaces come into contact at once.

#### 1.3.6 Limit Switch

It is a switch operated by the motion of a machine part or presence of an object. It is used for control of a machine, as safety interlocks, or to count objects passing a point. It is an electromechanical device that consists of an actuator mechanically linked to a set of contacts. When an object comes into contact with the actuator, the device operates the contacts to make or break an electrical connection. It is used in a variety of applications and environments because of their ruggedness, ease of installation, and reliability of operation. It can determine the presence or absence, passing, positioning and end of travel of an object. It was first used to define the limit of travel of an object, hence the name 'limit switch.'

#### 1.3.7 Control switch

It is used in order to start or stop the entire operation of the object lifting jack. The type of switch that is used is known as a toggle switch. The toggle switch is a class of electrical switches that are manually actuated by a mechanical lever, handle, or rocking mechanism. This is designed to provide the simultaneous actuation of multiple sets of electrical contacts, or the control of large amounts of electric current or mains voltages.

#### 1.3.8 Control cables

These are used in order to connect the battery to the motor and the switch.

#### 1.3.9 Base and Frame

A base for the entire set-up has also been made. The motor is mounted on an inverted U-shaped support frame. Ball rollers are attached to four ends of the base for movement and are electrically controlled by switch.

### 3.2 BATTERY

In isolated systems away from the grid, batteries are used for storage of excess solar energy converted into electrical energy. The only exceptions are isolated sunshine loads such as irrigation pumps or drinking water supplies for storage. In fact, for small units with

output less than one kilowatt. Batteries seem to be the only technically and economically available storage means. Since both the photovoltaic system and batteries are high in capital costs. It is necessary that the overall system be optimized with respect to available energy and local demand pattern. To be economically attractive the storage of solar electricity requires battery with a particular combination of properties:

### Battery Specification:

Capacity : 12V and 7.3 Ah

Rechargeable battery one

Charging time : 3 hour



**Fig3.2:Battery**

#### 1.4 Specification of parts

##### 1.4.1 D.C motor

Torque	10 Kg cm
Speed	150 rpm
Voltage supply	12 V
Type	D.C

##### 1.4.2 Lead Screw

Outer diameter (d <sub>o</sub> )	13.7 mm
Inner diameter (d <sub>i</sub> )	11 mm
Mean diameter (d)	12.7 mm
Pitch	2 mm

##### 1.4.3 Larger Gear

Addendum circle diameter	73.45 mm
Dedendum circle diameter	61.80 mm
Larger width of tooth	5.46 mm
Smaller width of tooth	1.44 mm
Depth of cut	6.45 mm
Thickness	12.95 mm

##### 1.4.4 Smaller Gear

Addendum circle diameter	44.95 mm
Dedendum circle diameter	32.52 mm
Larger width of tooth	4.76 mm
Smaller width of tooth	1.14 mm
Thickness	13.06 mm

##### 1.4.5 Roller

Torque	5 Kg cm
Speed	150 rpm
Voltage supply	12 V
Type	D.C
Number	2

##### 1.4.6 Base

Length	72.5 mm
Breadth	42.5 mm
Thickness	2 cm
Material used	Plywood

##### 1.4.7 Limit Switch

Number	2
Type	Roller type
Two way voltage supply	12 V

##### 1.4.8 Control Switch

Type	DPCO ( Double Pole Control Off)
------	---------------------------------

##### 1.4.9 Load Panel

Diameter	9.8 cm
Thickness	5 mm

### 3.3 LEAD ACID WET CELL

Where high values of load current are necessary, the lead-acid cell is the type most commonly used. The electrolyte is a dilute solution of sulfuric acid (H<sub>2</sub>SO<sub>4</sub>). In the application of battery power to start the engine in an auto mobile, for example, the load current to the starter motor is typically 200 to 400A. One cell has a nominal output of 2.1V, but lead-acid cells are often used in a series combination of three for a 6-V battery and six for a 12-V battery. The lead acid cell type is a secondary cell or storage cell, which can be recharged. The charge and discharge cycle can be repeated many times to restore the output voltage, as long as the cell is in good physical condition. However, heat with excessive charge and discharge currents short ends the useful life to about 3 to 5 years for an automobile battery. Of the different types of secondary cells, the lead-acid type has the highest output voltage, which allows fewer cells for a specified battery voltage.

### 3.4 PIN DIAGRAM

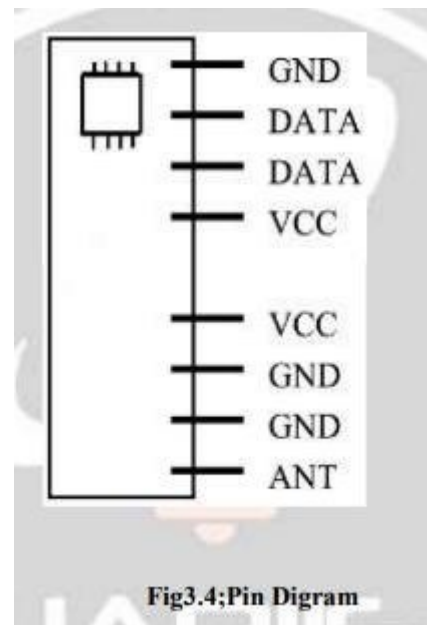

**Fig3.4:Pin Diagram**

#### 4.1.PIN DESCRIPTION:

**ANT:**

Antenna input.

**GND:** Receiver Ground. Connect to ground plane.

**VCC (5V):**

VCC pins are electrically connected and provide operating voltage for the Receiver. VCC can be applied to either or both. VCC should be bypassed with a  $.1\mu\text{F}$  ceramic capacitor. Noise on the power supply will degrade receiver sensitivity.

#### Antenna Input:

It will support most antenna types, including printed antennas integrated directly onto the PCB and simple single core wire of about 17cm. The performance of the different antennas varies. Any time a trace is longer than  $1/8$ th the wavelength of the frequency it is carrying, it should be a 50 ohm microstrip.

#### Applications:

- Car security system
- Sensor reporting
- Automation system
- Remote Keyless Entry (RKE)
- Remote Lighting Controls
- On-Site Paging

#### 3.5;POWER SUPPLY;

Power supply is a reference to a source of electrical power. A device or system that supplies electrical or other types of energy to an output load or group of loads is called a power supply unit or PSU. The term is most commonly applied to electrical energy supplies, less often to mechanical ones, and rarely to others. Power supplies for electronic devices can be broadly divided into linear and switching power supplies. The linear supply is a relatively simple design that becomes increasingly bulky and heavy for high current devices; voltage regulation in a linear supply can result in low efficiency. A switched-mode supply of the same rating as a linear supply will be smaller, is usually more efficient, but will be more complex.

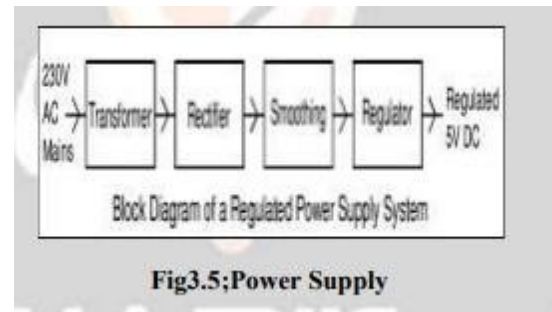

#### 3.6 TRANSFORMER:

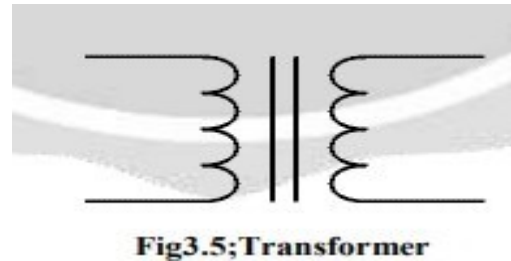

Transformers convert AC electricity from one voltage to another with little loss of power. Transformers work only with AC and this is one of the reasons why mains electricity is AC. Step-up transformers increase voltage, step-down transformers reduce voltage. Most power supplies use a step-down transformer to reduce the dangerously high mains voltage (230V in UK) to a safer low voltage. The input coil is called the primary and the output coil is called the secondary. There is no electrical connection between the two coils; instead they are linked by an alternating magnetic field created in the soft-iron core of the transformer. The two lines in the middle of the circuit symbol..

#### 3.7 PIC16F877A Microcontroller - Device Overview:

The PIC16F877 is one of the latest products from Microchip. It features all the components which modern microcontrollers normally have. For its low price, wide range of application, high quality and easy availability, it is an ideal solution in applications such as: the control of different processes in industry, machine control devices, measurement of different values etc.

#### Multiple Threaded Power Screws

Multiple threaded power screws are used in certain applications where higher travelling speed is required. They are also called multiple start screws

such as double-start or triple-start screws. These screws have two or more threads cut side by side, around the rod

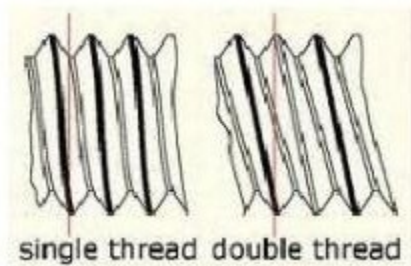

Multiple-start trapezoidal threads are designated

by letters „Tr“ followed by the nominal diameter and the lead ,separated by sign „x“ and in brackets the letter „P“ followed by the pitch expressed

in millimetres. For example,

#### 4. WORKING PRINCIPLE

##### 4.1 BLOCK DIAGRAM

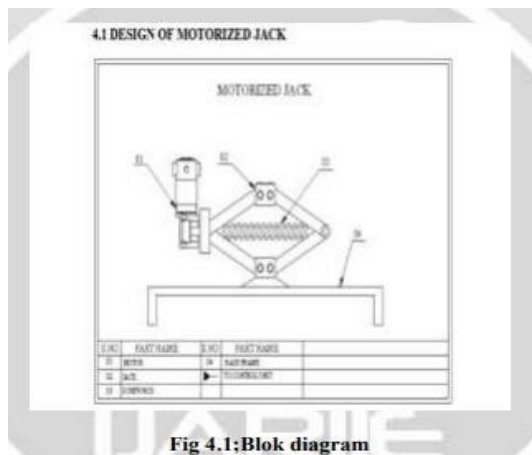

**Fig 4.1: Blok diagram**

The load on the screw is the load which is to be lifted  $W$ , twisting moment  $M$ , between the screw threads and force  $F$  at the handle to rotate the screw. The load  $W$  is compressive in nature and induces the compressive stress in the screw. It may also lead the screw to buckle. The load  $F$  produces bending and it is maximum, when the screw is at its maximum lift. The screw also experiences twisting moment due to  $F$ , the shear stress is also induced in the screw due to the twisting moment between the threads of screw and nut. Step I Problem Specification It is required to design an object lifting jack for supporting the machine parts during their repair and maintenance. It

should be a general purpose jack with a load carrying capacity of 50 KN and a maximum lifting height of 0.3m. The jack is so operated by means of a D.C motor. Step II Selection of Materials (i) The frame of the object lifting jack has complex shape. It is subjected to compressive stress. Grey cast iron is selected as the material for the frame. Cast iron is cheap and it can be given any complex shape without involving costly machining operations. Cast iron has higher compressive strength compared with steel. Therefore, it is technically and economically advantageous to use cast iron for the frame.

(ii) The screw is subjected to torsional moment, compressive force and bending moment. From strength consideration, EN8 is selected as material for screw. (iii) There is a relative motion between the screw and the nut, which results in friction. The friction causes wear at the contacting surfaces. When the same material is used for these two components, the surfaces of both components get worn out, requiring replacement. This is undesirable. The size and shape of the screw make it costly compared with the nut. The material used for the nut is stainless steel.

The object lifting jack is an intermittently use device and wear of threads is not an important consideration. Therefore, instead of trapezoidal threads, the screw is provided with square threads. Square threads have higher efficiency and provision can be made for self-locking arrangement. When the condition of self-locking is fulfilled, the load itself will not turn the screw and descend down, unless an effort in the reverse direction is applied.

#### CALCULATIONS

Observed data: Nominal diameter of screw,

$d = 13.7$  mm Core diameter of screw,

$d_c = 11$  mm Pitch of screw thread,

$p = 2$  mm Load  $W = 20$  kg Coefficient of friction,

$\mu = 0.15$  Mean diameter of screw,  $d_m = 12.7$  mm Helix angle of screw,

$\alpha = 2.680$  Tangential force required at the circumference of the screw to raise the load  $\mu = \tan \theta = 0.15$

#### Torque Requirement- Lifting Load

The screw is considered as an inclined plane with inclination  $\alpha$ . When the load is being raised,

following forces act at a point on this inclined plane:

(i)

Load  $W$

: It always acts in vertically downward direction. (ii)

Normal reaction  $N$

: It acts perpendicular (normal) to the inclined plane. (iii)

Frictional force  $\mu N$

: Frictional force acts opposite to the motion. Since the load is moving up the inclined plane, frictional force acts along the inclined plane in downward direction

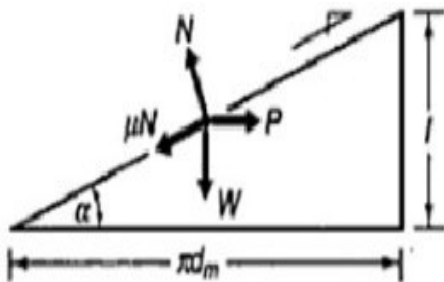
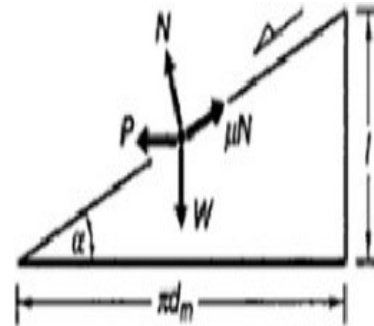

Torque Requirement- Lowering Load

When the load is being lowered, the following forces act at a point on the inclined plane: (i)

Load  $W$

: It always acts in vertically downward direction. (ii)

Normal reaction  $N$

: It acts perpendicular (normal) to the inclined plane. (iii)

Frictional force  $\mu N$

: Frictional force acts opposite to the motion. Since the load is moving down the inclined plane, frictional force acts along the inclined plane in upward direction

$$p = W \times \frac{\tan \alpha + \tan \phi}{1 - \tan \alpha \cdot \tan \phi} = 40.2 \text{ N}$$

$$\begin{aligned} \text{Torque required to operate the screw} &= p \times \frac{d}{2} + \mu r_m \\ &= 40.2 \times (12.7/2) + (0.15 \times 200 \times 18) \\ &= 825.27 \text{ N mm} = 0.8257 \text{ Nm} = 8.5 \text{ Kg cm} \end{aligned}$$

$$\begin{aligned} \text{Efficiency of the screw} &= T_0/T_1 \\ &= \frac{200 \times (12.7/2)}{0.15 \times 200 \times 18 + 200 \times (12.7/2)} = 27\% \end{aligned}$$

$$\begin{aligned} \text{For lowering load (P)} &= W \tan (\alpha + \phi) \\ &= W \times \frac{\tan \alpha + \tan \phi}{1 - \tan \alpha \cdot \tan \phi} = 19.826 \text{ N} \end{aligned}$$

$$\begin{aligned} \text{Torque} &= p \times \frac{d}{2} + \mu r_m \\ &= 0.662 \text{ N} \end{aligned}$$

$$\text{Shear stress due to torque } T_1, \tau = 16T_1/\pi(d_1)^3 = 825.27 \text{ N/mm}^2 = 3.15 \text{ N/mm}^2$$

$$\text{Compressive stress due to axial load } (\sigma_c) = W/A = 2.10 \text{ N/mm}^2$$

$$\text{Shear stress due to torque } (\sigma_{c \max}) = 0.5 [\sigma_c + \sqrt{\sigma_c^2 + 4\tau^2}] = 4.5 \text{ N/mm}^2 < 50 \text{ N/mm}^2$$

$$\text{Maximum shear stress} = 3.32 \text{ N/mm}^2 < 40 \text{ N/mm}^2$$

So, design is safe.

Spur Gear,

$$\text{Gear Ratio} = 1.75$$

$$T_p = 16 \quad T_g = 28$$

$$\text{Velocity ratio} = 0.571$$

$$N_p = 150 \quad N_g = 85.714$$

$$A_p = 44.95 \quad A_g = 73.45$$

$$D_p = 32.96 \quad D_g = 61.80$$

$$\begin{aligned} Y &= 0.175 - 0.841/\text{no. of teeth} \\ &= \frac{\pi \times m \times T_p \times N_g}{160} = 40 \text{ mm} \end{aligned}$$

Taking  $C_s = 1$

$$W_t = \frac{P \times C_s}{V} = \frac{15.40 \times 1}{0.12566} = 122.55$$

$$C_v = \frac{3}{3+v} = \frac{3}{3+0.12566} = 0.959$$

$$Y_p = 0.175 - \frac{0.84}{16} = 0.1224$$

$$\begin{aligned} Y_g &= 0.1449 \\ W_t &= \sigma_{wp} \times b \times \pi \times m \times Y_p \end{aligned}$$

$$\frac{15.40}{0.1256} = 60 \times 6 \times \pi \times 0.097 \times \frac{3}{3+0.12566}$$

$$46.2 + 1.93424 = 96.4521 \text{ m}^3$$

$m = 2.5$  standard

Addendum = 3.45 mm

Dedendum = 8.2 mm

Centre distance between the shaft = 55 mm

$$\begin{aligned} \text{Wear tooth load } (W_w) &= D_p \times b \times Q \times K \\ &= 40 \times 12.5 \times (14/11) \times 1.57 \\ &= 1000 \text{ N} \end{aligned}$$

$$\begin{aligned} \text{Dynamic Load } (W_d) &= W_t + W_i \\ &= \frac{21v(b_c + W_t)}{21v + \sqrt{b_c + W_t}} = 43.3 \text{ N} \end{aligned}$$

$$V = 0.341 \text{ m/s}$$

$$b = 12.5 \text{ mm}$$

$$C = \frac{K_c}{\frac{1}{E_p} + \frac{1}{E_g}} = 1063.4$$

$$W_d = 825.4 \text{ N}$$

Since  $W_d < W_w$ . Design is true.

$$W_s = \sigma_c \times b \times P_c \times y$$

$$\sigma_c = 80 \text{ N/mm}^2$$

$$b = 12.5 \text{ mm}$$

$$P = \pi m$$

$$Y = 0.1224$$

$$W_s = 958.185$$

$$W_s > W_D$$

It is true.

### WORKING MECHANISM:

STEP 1 The lead acid battery is used to drive the d.c motor. The d.c motor shaft is connected to the spur gear. If power is driven to the d.c motor, it will run so that the spur gear also runs to slow down the speed of the d.c motor. The object moving jack moves the lead screw upwards, so that the vehicle lifts from the ground. The vehicle is lifted by using the lifting platform at the top of the jack. The motor draws power supply from the battery. The lifting and uplifting is done by changing the battery supply to the motor.

STEP 2 After pressing the DPCO switch, the circuit is completed and from battery power is transferred to the motor that is connected to the roller. Now the roller starts moving. Now controlling the two number

of DPCO switch which is connected to the two motors at the base the whole set-up is adjusted below the body which is being lifted.

STEP 3 Now pressing the DPCO switch to the circuit which is connected to the motor that is coupled to the lead screw, the circuit is completed and voltage from the battery is pass to the motor. When tapping the switch to the positive pole, positive voltage is supplied to the d.c motor moves in clockwise direction and lead screw moves in downward direction.

STEP 4 When tapping the switch to the negative pole, negative voltage is supplied to the d.c motor moves in anticlockwise direction and lead screw moves in upward direction.

STEP 5 Now when the lead screw moves to the maximum limit, the limit switch at the upper end gets activated and the circuit gets cut-off. When the lead screw moves to the minimum limit, the limit switch at the bottom end gets activated and the circuit gets cut-off.

The weight acting on front and rear axle is 60% and 40% of total weight respectively, hence the weight acting on front axle i.e.; 900 kg is considered for designing the jack. A weight of 450 kg acts on each wheel. And the maximum load on screw act when jack is at its lowest position. We assumed the thread on screw be a Double Start Square thread and coefficient of friction between threads is 0.20. T 1 T 1

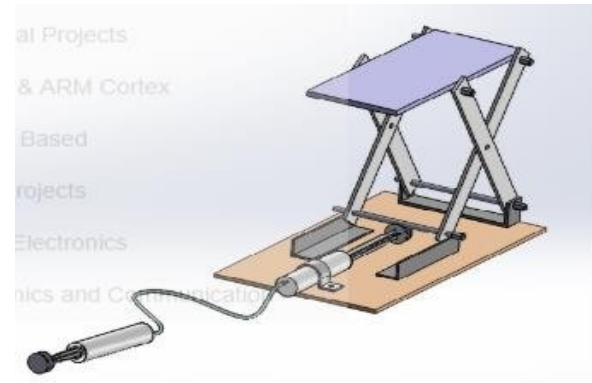

## Design Calculations

Length of each arm =  $L_1 = L_2 = L_3 = L_4 = 160\text{mm}$   
Length of the power screw =  $(w_1 + w_2 + w_3) = 350\text{mm}$   
 $w_1 = w_3 = 150\text{ mm}$   $w_2 = 50\text{ mm}$  Maximum lift of the jack =  $(h_1 + h_2) = 300\text{ mm}$   $\theta$  is the angle made by link with horizontal when jack is at its lowest

position.  $\cos(\theta) = (175 - 25) / 160 = 20.36^\circ$   $W = (\text{load} * g) = (450 * 10) = 4500\text{ N} = 4.5\text{ kN}$  The tension  $T$  acting on the power screw is shown in the above Fig 4.1. Tension,  $T = W / 2 * \tan(\theta)$  Total tension =  $2 * T = W / \tan(\theta)$  For a power screw under tension we can take  $\sigma_t = 124\text{ N/mm}^2$  for mild steel Let  $d_c$  be the core diameter of the screw. But load on the screw is  $\text{Load} = (\pi/4) * d_c^2 * \sigma_t$  So,  $2 * T = W / \tan(\theta) = (\pi/4) * d_c^2 * \sigma_t$   $2 * T = 4.5\text{ kN} / \tan(20.36^\circ) = 12123.44\text{ N}$   $d_c^2 = (W / \tan(\theta)) * (4 / (\pi * \sigma_t))$  Hence,  $d_c = 11.34\text{ mm}$  Since the screw is subjected to torsional shear stress we adopt,  $d_c = 14\text{ mm}$  Taking pitch,  $P = 2\text{ mm}$  Outer diameter,  $d_o = d_c + P = (14 + 2) = 16\text{ mm}$  Mean diameter,  $d = d_o - P/2 = 16 - 2/2 = 15\text{ mm}$  Check for self-locking  $\tan(\alpha) = \text{Lead} / \pi * d$ ;  $\alpha = \text{helix angle}$   $\text{Lead } L = 2 * P$ ; since the screw has a double start square thread.  $\tan(\alpha) = 2 * p / \pi * d = 2 * 2 / \pi * 15 = 0.084$  Helix angle;  $\alpha = 4.85^\circ$  Coefficient of friction;  $\mu = \tan(\phi) = 0.20$ ; friction angle;  $\phi = 11.3^\circ$

$\phi > \alpha$  hence the screw is self-locking Effort required to support the load =  $2 * T \tan(\phi + \alpha) = 12123.44 (\tan(\alpha) + \tan(\phi)) / (1 - (\tan(\alpha) * \tan(\phi))) = 3510.715\text{ N}$  Torque required to rotate the screw = effort \*  $d/2 = 3510.715 * 15/2 = 26330.36\text{ N-mm}$  Shear stress in the screw due to torque  $\tau = 16 * T / (\pi * d_c^3) = 16 * 26330.36 / (\pi * 14^3) = 48.87\text{ N/mm}^2$  But tensile stress  $\sigma_t = 2 * T / ((\pi/4) * d_c^2) = 12123.44 / ((\pi/4) * 14^2) = 78.755\text{ N/mm}^2$  Maximum principal stress  $\sigma_{t \text{ max}} = \sigma_t / 2 + \sqrt{(\sigma_t^2 + \tau^2) / 2} = 102.13\text{ N/mm}^2$  Maximum shear stress  $\tau_{\text{max}} = \sqrt{(\sigma_t^2 + \tau^2) / 2} = 62.76\text{ N/mm}^2$  Since the maximum stresses  $\sigma_{t \text{ max}}$  and  $\tau_{\text{max}}$  within the safe limits, the design of double started square threaded screw is satisfactory. Nut Material Selected Bronze Design Calculations Let  $n$  be the number of threads in contact with the screw assumed that load is Uniformly Distributed over the cross section area of the nut. Allowable Bearing pressure between the threads ( $P_b$ ) are Table Nut Parameters Material Screw Nut Safe Bearing pressure ( $\text{N/mm}^2$ ) Rubbing speed at thread pitch diameter Steel Bronze 12.6 - 17.5 Low speed < 2.4 m/min Steel C.I 11.2 - 17.5 Low speed < 3 m/min

Bearing pressure is assumed as  $15\text{ N/mm}^2$   $P_b = (2 * T) / ((\pi/4) * (d_o^2 - d_c^2) * n) = 15 = (12123.44) / ((\pi/4) * (16^2 - 14^2) * n)$  Number of threads,  $n = 10.6 \approx 11$  In order to have good stability let  $n = 11$  Thickness of Nut =  $n * p = 11 * 2 = 22\text{ mm}$  Width of Nut  $b = 1.5 * d_o = 1.5 * 16 = 24\text{ mm}$  To control the movement of nuts beyond 300 mm the rings of 8 mm thickness are fitted on the screw with the help of set screw The

length of screw portion =  $300 + (8 \times 2) + 22 = 338$  mm  
 $\approx 350$  mm Total length of screw is 350 mm. 4.3 Pins in Nut 4.3.1 Material selected Mild Steel 4.3.2 Design calculations Let  $d_1$  = diameter of pins in the nuts Since Pins are in double shear stress Load on pins =  $W/2 = 2 \times (\pi/4) \times d_1 \times 2 \times \tau = 12123.44/2$   $\tau$  = Shear stress = 50 MPa for steel Hence  $d_1 = 8.78$  mm  $\approx$  say 10 mm Diameter of pins head is taken as  $1.5 \times d_1 = 15$  mm and thickness be 4 mm 4.4 Top Arm 4.4.1 Material selected Mild Steel 4.4.2 Design calculations  $\sigma_{yt}$  for mild steel = 248 N/mm<sup>2</sup> Factor of safety (F.S) = 2.5  $\sigma_t = \sigma_{yt}/F.S = 248/2.5 = 99.2$  N/mm<sup>2</sup>  $\sigma_c = 1.25 \times \sigma_t = 1.25 \times 99.2 = 124$  N/mm<sup>2</sup>

26 Cross section area (A) =  $(40 \times 3) + (24 \times 3) + (40 \times 3) = 312$  mm<sup>2</sup> Moment of Inertia  $I_{xx} = 47376$  mm<sup>4</sup>,  $I_{yy} = 51009.38$  mm<sup>4</sup> Radius of Gyration  $R_x = 12.323$  mm,  $R_y = 12.786$  mm Rankine's constant (a) =  $1/7500$  Ends are hinged ( $L_{eff} = L$ ) Pcr in vertical plane  $\sigma_c =$  crippling stress = 330 N/mm<sup>2</sup>  $P_{cr} = (\sigma_c \times A) / (1 + a \times (L / R_y)^2) = (330 \times 312) / (1 + (1/7500) \times (160/12.786)^2) = 100854.26$  N Pcr in horizontal plane  $\sigma_c =$  crippling stress = 330 N/mm<sup>2</sup>  $P_{cr} = (\sigma_c \times A) / (1 + a \times (L / 2 \times R_x)^2) = (330 \times 160 \times 40) / (1 + (1/7500) \times (160/2 \times 12.323)^2) = 2100198.258$  N Since Buckling load is more than Design load the dimensions of the link safe. 4.5 Bottom Arm 4.5.1 Material selected Mild Steel 4.5.2 Design calculations  $\sigma_{yt}$  for mild steel = 248 N/mm<sup>2</sup> Factor of safety (F.S) = 2.5  $\sigma_t = \sigma_{yt}/F.S = 248/2.5 = 99.2$  N/mm<sup>2</sup>  $\sigma_c = 1.25 \times \sigma_t = 1.25 \times 99.2 = 124$  N/mm<sup>2</sup> Cross section area (A) =  $(40 \times 3) + (30 \times 3) + (40 \times 3) = 330$  mm<sup>2</sup> Moment of Inertia  $I_{xx} = 72270$  mm<sup>4</sup>,  $I_{yy} = 54469.31$  mm<sup>4</sup> Radius of Gyration  $R_x = 14.79$  mm,  $R_y = 12.84$  mm Rankine's constant (a) =  $1/7500$  Ends are hinged ( $L_{eff} = L$ ) Pcr in vertical plane  $\sigma_c =$  crippling stress = 330 N/mm<sup>2</sup>  $P_{cr} = (\sigma_c \times A) / (1 + a \times (L / R_y)^2) = (330 \times 330) / (1 + (1/7500) \times (160/12.84)^2) = 106691.09$  N Pcr in horizontal plane  $\sigma_c =$  crippling stress = 330 N/mm<sup>2</sup>  $P_{cr} = (\sigma_c \times A) / (1 + a \times (L / 2 \times R_x)^2) = (330 \times 160 \times 40) / (1 + (1/7500) \times (160/2 \times 14.8)^2) = 2103804.02$  N Since Buckling load is more than Design load the dimensions of the link safe. 4.6 Top Plate (Loading Platform) 4.6.1 Material used Mild Steel 4.6.2 Design calculations Moment,  $M = (p \times l) / 4$   $p = 5000$  N  $l = 50$  mm  $M = (5000 \times 50) / 4 = 250000 / 4 = 62500$  N-mm  $Z = (b \times h^2) / 6 = (36 \times 40^2) / 6 = 9600$  mm<sup>3</sup>  $b = 36$  mm,  $h = 40$  mm  $\sigma_b = M / Z = 62500 / 9600 = 6.51$  N/mm<sup>2</sup> Conclusion The permissible stress for mild steel is 124 N/mm<sup>2</sup> and it is greater than  $\sigma_b = 6.51$  N/mm<sup>2</sup> The top plate design is safe. 4.7 Bottom Plate (Support) 4.7.1 Material used Mild Steel The

size and shape of the bottom plate have been selected to provide the stability to the power Scissor Jack. Fixing the dimensions of bottom plate as  $120 \times 70 \times 3$  all in mm.



## MANUFACTURING METHODS

This process gives quite fast production by using suitable thread milling cutters in centre lathes as indicated in Fig 6.5. The milling attachment is mounted on the saddle of the lathe. Thread milling is of two types (a) Long thread milling (b) Short thread milling Fig 6.5 Thread milling by attachment in center lathes o Long thread milling Long and large diameter screws like machine lead screws are reasonably accurately made by using a large disc type form milling cutter as shown in Fig 6.5. o Short thread milling Threads of shorter length and fine pitch are machined at high production rate by using a HSS milling cutter having a number of annular threads with axial grooves cut on it for generating cutting edges. Each job requires only around 1.25 revolution of the blank and very short axial (1.25 pitch) and radial (1.5 pitch) travel of the rotating tool  $\Delta$  Rotating tool Often it becomes necessary to machine large threads on one or very few pieces of heavy blanks of irregular size and shape like heavy casting or forging of odd size and shape. In such cases, the blank is mounted on face plate in a center lathe with proper alignment. The deep and wide threads are produced by intermittent cutting action by a rotating tool. A separate attachment<sup>44</sup> carrying the rotating tool is mounted on the saddle and fed as usual by the lead screw of the center lathe. Fig 6.6 shows schematically the principles of threading by rotary tools. The tool is rotated fast but the blank much slowly. This intermittent cut enables more effective lubrication and cooling of the tool. Fig 6.6 Thread cutting in center lathe by rotating tools o Internal threads Internal threads are produced in center lathes at slow rate by using;  $\Delta$  Single point tool  $\Delta$  Machine taps  $\Delta$  Internal thread milling  $\Delta$  Internal threading by single point chasing Internal

threads in parts of wide ranges of diameter and pitch are accurately done in centre lathes by single point tool, as in boring, as shown in Fig 6.7 (a). Multipoint flat chaser is often used for faster production.

(a) (b) (c) Fig 6.7 (a) single point tool, (b) solid tap and (c) milling cutter for internal threading in center lathe  
 Δ Internal threading by taps Internal threads of small length and diameter are cut in drilled holes by different types of taps;  
 Δ Straight solid tap (Fig 6.7 (b) – used for small jobs  
 Δ Taps with adjustable blades – usually for large diameter jobs  
 Δ Taper or nut taps – used for cutting threads in nuts.  
 Δ Internal thread milling cutter Such solid cutter, shown in Fig 6.7 (c) produces internal threads very rapidly, as in external short thread milling, in lathes or special purpose thread milling machine. (b) Machining threads in semiautomatic lathes Both external and internal threads are cut, for batch or small lot production, in capstan and turret lathes using different types of thread cutting tools.

Δ External threads in capstan lathe by self-opening die and single or multipoint chaser in turret lathe  
 Δ Internal threads of varying size by collapsible tap. The self-opening die, typically (a), is mounted in the turret and moved forward towards the rotating blank. At the end point, when the turret slows down and is about to stop or reverse, the front position of the die gets pulled and open automatically to enable free return of the die without stopping the job – rotation. The thread chasers may be flat or circular type as shown. In a collapsible tap, shown in Fig 6.8 (b), the radially raised blades collapse (move radially inward) and the tap returns (along with the turret or saddle) freely from the threaded hole after completing the internal thread in one stroke. (a) (b) Fig 6.8 Cutting (a) external and (b) internal threads in capstan and turret lathes (c) Machining threads in automatic lathes Small external threads for mass production of fasteners are produced by machining in single spindle automatic lathes or similar but special purpose (threading) lathes using solid die. The die is mounted on the coaxially moving turret or sliding attachment in turret lathes and SPM respectively. In turret lathe, the solid die is returned by reversing the job rotation, and in the special purpose machine, the die is freely returned by rotating the die slightly faster than the job and in the same direction.

(d) Machining screw threads in drilling machine Drilling machines are used basically for originating cylindrical holes but are also used, if needed, for enlarging drilled holes by larger drills, counter

boring, countersinking etc. Internal threads of relatively smaller diameter, length and pitch are also often produced in drilling machines by using tapping attachment with its taper shank fitted axially in the spindle bore. Fig 6.9 typically shows one such tapping attachment. Fig 6.9 Tapping attachment for machining internal threads in drilling machines The tapping attachment is pushed slowly inside the drilled hole at low speed for cutting threads and at the end of this stroke, it is withdrawn slowly by rotating in reversed direction. Just at the point of start of return, the lower part of the attachments momentarily gets delinked from the upper part and is then up and rotated respectively by the spring and the clutch as shown in Fig 6.9 to move at per with the upper part fitted into the spindle. This is necessary for the safe return of the tap without damaging the through or blind hole. Threading of small identical components like nuts for its mass production is also possible and done in general purpose drilling machines by using special attachment as shown in Fig 6.10. The taper tap is connected with a bent rod which is made to rotate at high speed along with the spindle causing rotation of the tap at the same speed. The blanks are automatically pushed intermittently under the tap and after threading the tap returns but along with the threaded nut. Finally the accumulated nuts are thrown out from the rod by centrifugal force to come out from the hopper as shown.

Sequence of operations on top and bottom arms S no. Machine Operation Tools Time (min)  
 1 Stores Check the raw material Try square, steel rule, and dot punch 20  
 2 Welding shop Welding of a flat plate to the angular to obtain channel section. Welding gun, Files and Emery paper 120  
 3 Grinding machine Grinding the plate in vice Grinding wheel 60  
 4 Radial Drilling machine Drilling 10 mm holes at both the ends of the plate Drill bit, dot punch, hammer and steel rule 40  
 7.2 Power Screw A circular rod was turned to the required dimensions in a lathe machine and then we have adjusted the lathe machine in order to obtain external square threads and thus the external square threads of required dimensions were obtained as shown in the Fabrication of power screw on lathe

Sequence of operations on power screw S no. Machine Operation Tools Time (min)  
 1 Stores Check the raw material Outer calipers, steel rule 5  
 2 Sawing machine Cutting the length of the rod as per requirement Hack saw 25  
 3 Lathe machine Turning the diameter to 16 mm Single point cutting tool 35  
 4 Lathe machine Threading of square thread Threading tool 60  
 5 Shop Floor Inspection Vernier calipers 5

7.3 Trunions A circular rod was drilled to form a through hole. Then the hole has been finished to form internal square threads corresponding to the external threads of the power screw so that the internal square threads of the trunions mate with the external threads of the power screw as shown in the Fig 7.3. Fig 7.3 Trunions with internal threading

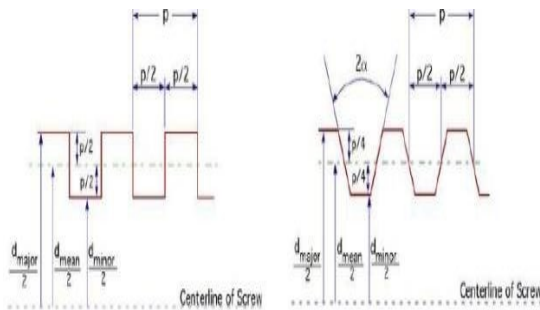

Sequence of operations on power screw S no. Machine Operation Tools Time (min) 1 Stores Check the raw material Outer calipers, steel rule 5 2 Sawing machine Cutting the length of the rod as per requirement Hack saw 25 3 Lathe machine Turning the diameter to 16 mm Single point cutting tool 35 4 Lathe machine Threading of square thread Threading tool 60 5 Shop Floor Inspection Vernier calipers 5 7.3 Trunions A circular rod was drilled to form a through hole. Then the hole has been finished to form internal square threads corresponding to the external threads of the power screw so that the internal square threads of the trunions mate with the external threads of the power screw as shown in the Fig 7.3. Fig 7.3 Trunions with internal threading

Sequence of operations on Trunion S no. Machine Operation Tools Time (min) 1 Stores Check the raw material Inner calipers, steel rule 5 2 Sawing machine Cutting the length of the rod as per requirement Hack saw 25 3 Lathe machine Turning the outer diameter to 24 mm Single point cutting tool 35 4 Lathe machine Boring the Trunions to 16mm diameter Boring tool 15 5 Lathe machine Threading of square thread Internal Threading tool 60 6 Shop Floor Inspection Vernier calipers 5 7.4 Top and Bottom Plates The left out pieces of the channel sections of the arms have been used for the top plate and then holes were drilled to the plate for fasteners connecting top plate and the arms. The top plate is fabricated in order to act as a loading platform as shown on the Fig 7.4. The bottom plate was fabricated by welding two L-angles so that the bottom arms fit into the bottom plate. The bottom

plate is fabricated in order to obtain maximum stability to the Power Scissor Jack. Fig 7.4 Top Plate and Bottom plate

Sequence of operations on top and bottom plates S no. Machine Operation Tools Time (min) 1 Stores Check the raw material Try square, steel rule, dot punch 15 2 Welding shop Welding of a flat plate to the angular to obtain channel section. Welding gun, Files and Emery paper 120 3 Grinding machine Grinding the plate in vice Grinding wheel 90 4 Radial Drilling machine Drilling 10 mm holes at both the ends of the plate Drill bit, dot punch, hammer and steel rule 60 5 Shop Floor Inspection Vernier calipers 10 7.5 Power Gun It has been purchased to drive the power screw by providing a suitable slot in the head of the power screw. 7.6 Light Source A LED bulb is fitted to the base plate to facilitate the repairs during the night times. 7.7 Power Source Both power gun and light source can be activated through the battery of the automobile.

## 1 Applications

The main applications of power screws are as follows:

- To raise the load, e.g. screw-jack,
- (ii) To obtain accurate motion in machining operations, e.g. lead-screw of lathe,
- (iii) To clamp a workpiece, e.g. vice, and
- (iv) To load a specimen, e.g. universal testing machine. There are three essential parts of a power screw, viz. screw, nut and a part to hold either the screw or the nut in its place. Depending upon the holding arrangement, power screws operate in two different ways. In some cases, the screw rotates in its bearing, while the nut has axial motion. The lead screw of the lathe is an example of this category. In other applications, the nut is kept stationary and the screw moves in axial direction. Screw-jack and machine vice are the examples of this category.

## Advantages:

Power screws offer the following advantages:

1. The loaded light vehicles can be easily lifted.
2. Checking and cleaning are easy, because the main parts are screwed.

3. Handling is easy
4. No Manual power required.
5. Easy to Repair.
6. Replacement of parts are easy

Power screw has large load carrying capacity.

(ii) The overall dimensions of the power screw are small, resulting in compact construction.

(iii) Power screw is simple to design

(iv) The manufacturing of power screw is easy without requiring specialized machinery. Square threads are turned on lathe. Trapezoidal threads are manufactured on thread milling machine.

(v) Power screw provides large mechanical advantage. A load of 15 kN can be raised by applying an effort as small as 400 N. Therefore, most of the power screws used in various applications like screw-jacks, clamps, valves and vices are usually manually operated.

(vi) Power screws provide precisely controlled and highly accurate linear motion required in machine tool applications.

(vii) Power screws give smooth and noiseless service without any maintenance.

(viii) There are only a few parts in power screw. This reduces cost and increases reliability

### Dis Advantages:

Cost of the equipment is high when compared to ordinary hand jack.

Care must be taken for the handling the equipment such as proper wiring connection, battery charging checkup, etc

The disadvantages of power screws are as follows:

Power screws have very poor efficiency; as low as 40%. Therefore, it is not used in continuous power transmission in machine tools, with the exception of the lead screw. Power screws are mainly used for intermittent motion that is occasionally required for lifting the load or actuating the mechanism.

(ii) High friction in threads causes rapid wear of the screw or the nut. In case of square threads, the nut is usually made of soft material and replaced when

worn out. In trapezoidal threads, a split-type of nut is used to compensate for the wear. Therefore, wear is a serious problem in power screws

### Conclusion

It was an impressive undertaking in the realm of automobiles and vehicle workshops that was carried out by Workers in the car shop and service station benefit greatly from the opportunity to work together. The company has also saved money as a result of this initiative. As a result of the project's design, all of the required tasks have been completed, as well as providing In order to move things weighing as little as two kilos all the way up to hundreds of tonnes, object lifting jacks are the right tool. There has been a long-standing need for a better portable jack for automobiles. If a jack that can be operated from within the car or from a safe area off the road becomes available, it is extremely desired. As long as the jack is light and compact, it can be kept in a car trunk, lifted and carried by most people, and capable of lifting up to 4000-5000 pound vehicles off the ground, it is a good fit for the job. The jacking mechanism should be safe and easy to use, and it should be able to be operated from a safe distance. An easy-to-reach location under the vehicle's axle or a strengthened support surface built for a jack are ideal. All of these considerations were taken into consideration while developing the product. There are several advantages to using this kind of motorised automated object lifting jack for large weights.

### References

1. Giuseppe (1993) *ASM metals reference book (3rd edn)*. ASM International Materials, Park OH.
2. Murray and Takakazu [ (1996) *ASM specialty handbook - carbon and alloy steels*. ASM International Metals, Park OH.
3. Morales R (1982) *Engineering properties of steel*. American Society for Metals, Park OH. 4. Simpson (1990) *Metals handbook properties and selection: Ironssteels and highperformance*
- M.M. Noor, K. Kadirgama and M.M. Rahman, *Analysis Of Auto Car Jack, National Conference in Mechanical Engineering Research and Postgraduate Students, FKM Conference Hall, UMP, Kuantan, Pahang, Malaysia, 26-27 May 2010, 198-203.*
- [2] Mohd Abuzaid, Mohd Hasnain, ShabajAlam, Sohail Khan and Surendra Agarwal, *Inbuilt Hydraulic jack in Automobile vehicles, International Journal of Innovations in Engineering and Technology, 2(2),2013,76-84.*

[3] Tarachand G. Lokhande, Ashwin S. Chatpalliwar and Amar A. Bhoyar, *Optimizing Efficiency of Square Threaded Mechanical Screw Jack by Varying Helix Angle*, *International Journal of Modern Engineering Research*, 2(1), 2012, 504-508.

[4] P.S. Rana, P.H. Belge, N.A. Nagrare, C.A. Padwad, P.R. Daga, K.B. Deshbhratar and N.K. Mandavgade, *European Journal of Applied Engineering and Scientific Research*, 1 (4), 2012,167-172.

[5] Prashant Kumar Srivastav, Vipin Kumar Pandey, Shailesh Kumar Maurya, Ajit Tiwari, Jawed Rafiq and S.K. Dwivedi, *Highly Efficient Motorized Screw Jack*, *International Journal of Computational Engineering Research*, 3(5), 2013, 35-41.

[6] A. S. Akinwonmi and A. Mohammed, *Modification of the Existing Design of a Car Jack*, *Journal of Emerging Trends in Engineering and Applied Sciences*, 3 (4), 2012, 581-588.

[7] J.J. Ferreira, M.G. Boocock and M.I. Gray, *Review of the risks associated with pushing and pulling heavy loads (Health and Safety Laboratory Broad Lane Sheffield S3 7HQ, 2004)*.