



IJITCE

ISSN 2347- 3657

International Journal of Information Technology & Computer Engineering

www.ijitce.com



Email : ijitce.editor@gmail.com or editor@ijitce.com

Enhancing Power Quality in Photovoltaic System Grid Integration Using Machine Learning and Cascade Multilevel Inverters

Narendra Babu Kattepogu¹, Nageswara Rao Sikha¹, Pandraju Harshitha Naga Sandhya², Kolabathula
Gagan Srikanth², Nimmagadda Siddhu², Melody Jetti²

¹Assistant Professor, Department of Electrical and Electronics Engineering, SRK Institute of Technology-Enikepadu,
Vijayawada-521108, Andhra Pradesh, India

²Department of Electrical and Electronics Engineering, SRK Institute of Technology-Enikepadu, Vijayawada-521108,
Andhra Pradesh, India

Abstract:

The incorporation of photovoltaic (PV) systems into the electrical grid poses both challenges and opportunities with regards to power quality and system stability. With the increasing demand for renewable energy sources, it is crucial to enhance the efficiency and dependability of these systems, while also assuring their interoperability with the current grid architecture. This work aims to overcome these issues by introducing a new method that integrates a cascade multilevel inverter (CMI) with machine learning (ML) optimization techniques. The objective is to improve the integration of photovoltaic (PV) systems into the grid and enhance power quality. The proposed system architecture utilizes a cascade multilevel inverter, known for its capability to generate high-quality output waveforms with little harmonic distortion. This is essential for ensuring power quality when integrating PV systems into the grid. The findings indicate a substantial enhancement in the quality of electrical power when employing the machine learning-optimized CMI. This is evidenced by considerable reductions in total harmonic distortion (THD) and improved voltage stability, surpassing the performance of conventional inverter technologies. The proposed solution's performance and efficacy are validated through extensive simulations carried out in MATLAB.

Keywords: Photovoltaic Systems, Grid Integration, Cascade Multilevel Inverter, Machine Learning, Power Quality, Total Harmonic Distortion, Renewable Energy

Introduction:

The global energy landscape is witnessing a paradigm shift towards renewable energy sources, driven by the dual imperatives of reducing carbon emissions and mitigating the effects of climate change. Solar energy, harnessed through photovoltaic (PV) systems, emerges as a pivotal solution due to its ubiquity and sustainability. The integration of PV systems into the power grid is crucial for achieving a diversified and resilient energy mix, capable of meeting the world's increasing power demands sustainably.

In the smart era, microprocessor-controlled devices or digital, electronic, and nonlinear devices are extensively used in all sectors of the industry. Nearly all these devices are sensitive, have electrical supply disruptions at any minute, and cannot be operated properly. In addition, several supplies have also been increased, which degrades power quality (PQ). Problems that happen because of inadequate power quality are data errors, automatic resets, memory losses, UPS alarms, equipment failures, software corruptions, circuit board failures, power supply problems, and overheating of electrical distribution systems. Considering these realities, PQ has become progressively critical. Not only PQ issues but also the issues related to voltage are also most important from sensitive nonlinear loads and end-users [1,2].

The use of sensitive loads such as diagnostic equipment in health centers, educational institutions, and detention centers over several years has been fourfold, which leads to a concern with the quality of power of sensitive loads [3]. If power quality is insufficient, serious economic losses, losses in manufacturing, outage of sensitive and critical loads, and lack of information could have serious consequences [4]. Consequently, high power quality is essential for utilities, customers, and producers of electrical appliances too. The essential power quality issues include voltage swells, sags, harmonics, transients, flickers, fluctuations, and interruptions [5]. These are discussed in the next section. The sensitive and critical loads must prevent these issues in terms of power quality and voltage disturbances. In this regard, a wide range of solutions has been introduced including the best and most efficient solution for the compensation and mitigation of voltage disturbance known as custom power devices (CPDs) [6]. They act as compensating devices, each with its own control and application. CPDs such as a parallel-connected distribution static synchronous compensator (DSTATCOM), are used for correcting the power factor; for voltage compensation, the dynamic voltage restorer (DVR) is used and is connected in series; a parallel-series connected unified power quality conditioner (UPQC) can simultaneously inject voltage in series and current in parallel; however, UPQC and DSTATCOM are larger and more expensive, rather than DVR [7]. In modern power systems, the most serious and usual power quality issues are voltage sags, and DVR is used as the least expensive voltage sag solution [8].

When a voltage disturbance occurs on the supply side, the DVR supplies the required voltage to the load side. The DVR also protects from supply-side disturbances to sensitive and critical loads [9,10]. This means that the DVR is important to compensate for voltage sags and to protect the sensitive load. The DVR is the best CPD since it has low costs, has small sizes, and can respond quickly to voltage disturbances. As an example, the DVR installation cost for the 2–10 MVA power supply is USD 300/kVA, while uninterruptible power supplies (UPSs) installation costs are USD 500/kVA. The servicing and operating costs of DVR are approximately 5% of its capital investment; however, it is much higher (about 15%) [1]. UPQC is a DSTATCOM-DVR combination with two power converters; hence, the structure of the DVR is, therefore, less than UPQC. DVR and DSTATCOM are closely related; however, DVR is used to protect the sensitive loads from supply interruptions, whereas DSTATCOM is used to protect critical loads from load-side disturbances. Furthermore, the DVR quickly (less than 1/4 cycle) responds to voltage disturbances, unlike other CPDs, such as the static VAR compensator (SVC) (2-3 cycle) [11].

Power Quality Issues in Grid-Connected Renewable Energy Sources

There is considerable global attention to the utilization of renewable energy sources (RESs) for electricity generation. This is because of the negative environmental effects of fossil fuels being burned to convert energy, which emits an enormous amount of CO₂ and other greenhouse gases into the air. Figure 1 depicts a few of the renewable energy sources.

Renewable energy use rose by 3 percent as the demand for all other fuels declined, according to the IEA, Paris World Energy Review 2021 [18]. The main driver was a 7 percent increase in renewable energy generation. Renewable energy accounts for a 29% share of global electricity production in 2020, up from 27% in 2019. In 2021, the production of renewable energy will be more than 8% expanding to 8,300 TWh, the fastest growth year-on-year since the 1970s. Two-thirds of the renewable energy growth will be supported by solar PV and wind. The growth of renewable energy alone in China in 2021 was almost half expected, followed by the USA, the EU, and India shown in Figure 2. The wind is set to grow by 275 TWh (almost 17 percent), the greatest increase in renewable energy production, which is significantly higher than in 2020. China will remain the biggest market for PV, and there is expansion in the United States with ongoing federal and state policy support. The new solar PV capacity additions will recover rapidly from COVID-19-related delays in India in 2021, with strong policy support in Brazil and Vietnam driven by large political support for distributed solar PV applications. The new solar PV capacities increased in Brazil and Vietnam. The total electricity generated by solar photovoltaic systems in 2021 is projected to grow to 145 TWh or almost 18 percent. Renewable sources in the electricity generation mix are expected to increase their proportion by 30 percent in 2021, all the time from

all renewable sources. In combination with nuclear, carbon-free sources, the world coal plants' output in 2021 is much higher than that.

According to the IEA's 2021 Renewable Energy Market Update [19], renewable energy is the only power source for which consumption has risen despite the pandemic by 2020, while other fuel consumption has decreased. In light of current commercial and political changes, the renewable energy market investigates new global renewable power add-ons for 2021 and 2022. It also establishes a modern biofuel production prediction for these years, as the industry experienced significant losses due to a fall in transportation demand during the pandemic. It is expected to maintain the exceptional level of renewable energy add-ons and that 270 GW will become operational in 2021 and 280 GW in 2022. This expansion is

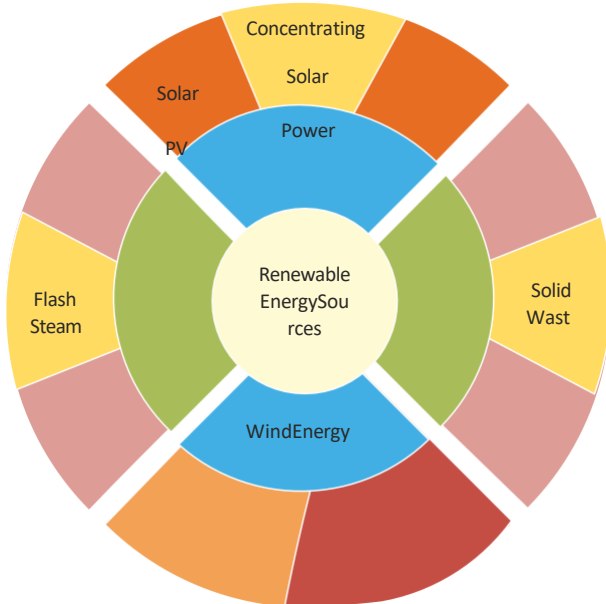

Major renewable energy sources.

Requirements for Grid-Integrated RES. Although some renewable energy sources are linked to the transmission system, most of them are linked to the distribution system. The operators of both distribution (DSOs) and transmission systems (TSOs) have been facing significantly higher levels of penetration of renewable sources, especially PV and wind systems, and many other strategies to replace conventional power plants with RES have been launched [20]. These changes have forced electrical system operators to take into account the impact of that penetration on grid stability. TSOs and DSOs have introduced new regulations at PCC, a common point of connection between the power grid and RES [21, 22]. RESs have the potential to handle various disturbances, increase the stability of voltage and frequencies and reliability, and improve power quality and security of power grids; they are required to act as traditional power plants [23]. The new requirements include standards of PCC power quality [24], voltage regulation [25], frequency regulation [26,27], voltage stability support through reactive power injection [28], frequency stability support through active power control [26,27], and voltage ride through (VRT) [29–34]. VRT is further subcategorized into (i) LVRT (low-voltage ride through) [30], (ii) ZVRT (zero-voltage ride through) [33], and (iii) HVRT (high-voltage ride through) [34]. In [30], the energy storage system was controlled by LVRT, and reactive power supports the grid; the limitations are overshooting, high fluctuations, superimposition, additional investment costs, periodic inspection, and maintenance, as specified in the grid code, whereas in [32], STATCOM and SVC control the LVRT; it injects reactive currents and improves the VRT capacity; however, there are no data about the change of DC-link voltage during grid faults; also, the complexity and costs increase. Voltage ride-through standards in different countries are tabulated in Table 1.

Power Quality. Power quality for electricity suppliers and their customers has become an important concern. From the point of view of customers, the consequences of disturbances in terms of financial loss can be between

hundreds to millions of dollars. Power quality issues lead to losses of consumer satisfaction and also losses of load or income from the point of view of utilities. Quick incidents such as voltage transients, swells/sags, voltage impulses, high-frequency noise, and faults are power quality issues; generally, these are identified as any deviation from the standard voltage source. Hence, issues of power quality affect electrical equipment directly [35–37]. The percentage sharing of major power quality issues is shown in Figure 4.

Disturbances that could lead to problems with power

quality may be an operation of unbalanced and nonlinear loads, start or switch off huge loads such as motors, energization of transformers and capacitor banks, or failure of devices such as transformers and wires, lightning, and natural events. The two main standards for power quality issues are the IEC and the IEEE. Table 2 contains the latest revisions to these standards [38–48], and the time required for RES to clear the abnormalities when exposed to abnormal voltage and frequency [49] is listed in Table 3.

Table 4 lists the most important issues of power quality and their definitions, and Table 5 provides reasons and effects of problems of power quality together with their duration and magnitude. IEC 61000-3-2 (1995-03), IEEE- 519, and IEC/TS 61000-3-4 (1998-10) establish guidelines for limiting harmonic problems. IEEE P1564 and P1547a address the voltage sag issues. The first deals with the impacts of voltage sag, while the second deals with ways to stabilize a system through voltage sag mitigation. The flicker problem characterizes IEC 61000-4-15. IEEE 1159–1995 characterizes general problems with power quality. IEEE 1250–1995 and IEEE P1409 discuss the impacts and corresponding solutions on power quality issues. IEEE Standard P1547 discusses microgrid characteristics and their interconnections with the power system.

Power Quality Improvement (PQI) Techniques. Various PQI research aimed at minimizing problems with PQs are reported, and the ideal grid integration of renewable energy sources is promoted; however, every mitigation technique creates certain difficulties; hence, it will continue to be an active research sector in the future too. Current quality improvement (CQI) and voltage quality improvement (VQI) strategies are two types of PQI techniques that emphasize renewable energy integration, as shown in Figure 5. The VQI technology addresses voltage variations and frequency mitigation in DGs. Further subclassifications of VQI techniques may include energy storage (ES) [50], custom power devices (CPDs) [51], optimization of energy conversion [52,53], spinning reserve [54], and a few additional unique technologies based on the variable frequency transformer (VFT) [55] and the virtual sync machine [56]. Further CQI technologies can be divided into passive filters (PFs) [57], active power filters (shunt and series) [58], smart impedance [59], hybrid filters [60], and multifunctional DGs [61].

Custom Power Devices (CPDs). Critical equipment protection against voltage sags and interruption is supplied with storage units. Examples of storage systems include flywheel energy storage system (FESS), superconducting magnetic energy storage (SMES), uninterruptible power supply (UPS), ultracapacitors (UCAPs), and batteries. They are used to mitigate the required energy due to faults and voltage drops. The most efficient method of mitigating voltage sags is by using custom power devices (CPDs); they ensure that the quality and reliability of supply are guaranteed to customers [62,63]. Table 6 contains the most important CPDs to mitigate the issues related to power quality

Dynamic Voltage Restorer

DVR is a compensating device having a series impedance that is serially connected between the PCC (point of common coupling) and the load as shown in Figure 6. It supplies the required voltage during sag to synchronize the load voltage and permits the switching of real and reactive power between DVR and distribution systems [64]. Westinghouse manufacturing company (part of Siemens) introduced the first DVR in August 1996, with the support of the Electric Power Research Institute (EPRI), with an installed capacity of 2MVA at Duke Power Company located in North

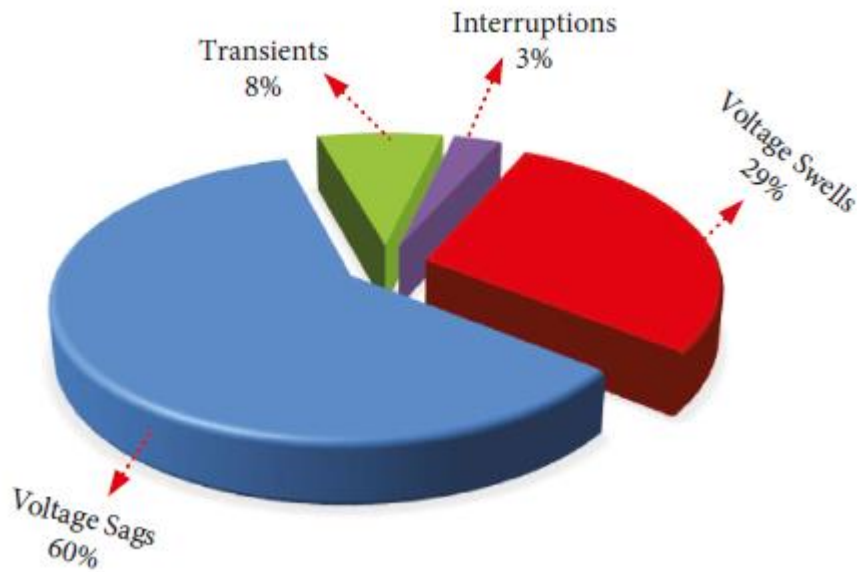

Percentage quantity of major PQ problems

Carolina (USA) on 12.47 kV distribution systems having three voltage source inverters and three injection transformers with the in-phase compensation technique [10, 15]. The equivalent circuit of DVR is obtained by connecting a voltage source V_{Comp} in between the source (VS) and load

(VL) with their respective impedances Z_S and Z_L as shown in Figure 7. At PCC source, the current I_S is divided into I_L and I_{OT} , where I_L is the sensitive load current and I_{OT} is another load current. The voltage at PCC is represented by V_G , and the voltage compensated by DVR is V_{DVR} . Resistance R and inductance L are obtained from the impedance Z of the filter and injection transformer, and the values of R_{DVR} and X_{DVR} are related to V_{DVR} . The impedance of the source, load, and DVR are Z_S , Z_L , and Z_{DVR} , respectively. P_S is the real power, and Q_S is the reactive power of supply. P_L is the real power, and Q_L is the reactive power of the load. P_{DVR} is the real power, and Q_{DVR} is the reactive power supplied by the DVR. The voltage across sensitive load VL is given by

$$V_L(t) = V_G(t) + V_{DVR}(t) + R i_L(t) + L \frac{di_L}{dt},$$

$$X_{DVR} = \frac{V_{DVR}^2}{S_{DVR}} X_{p.u.},$$

$$R_{DVR} = \frac{V_{DVR}^2}{S_{DVR}} R_{p.u.},$$

$$Z_{DVR} = \frac{V_{DVR}^2}{S_{DVR}} Z_{p.u.}$$

(1)

percentage of voltage handling capacity u_{DVR} and current handling capacity i_{DVR} of DVR is given by

$$u_{DVR} \% = \frac{V_{DVR}}{V_{s, rated}} 100\%,$$

$$i_{DVR} \% = \frac{I_{DVR}}{I_{L, rated}} 100\%.$$

(2)

- DVR mainly consists of a bypass switch, injection transformer, filter, inverter, and DC-link capacitor or energy storage as shown in Figure 8. DVR can be categorized into 1 ϕ DVR shown in Figure 8 and 3 ϕ DVR shown in Figure 9. A bypass switch is used to connect the DVR to the line during the injection mode and disconnect the DVR under standby operation. The injection transformer will adjust the DVR output voltage and isolate DC to AC systems. High-frequency harmonics present in DVR output voltage to attenuate this LC filter are used. The voltage is maintained as constant during transient by using a DC-link capacitor; hence, a steady-state operating

range of DVR will improve. For deep voltage sags, the external energy storage supplies the desired real power to the load. The most essential part of DVR is the inverter; it produces the required controllable voltage for compensation.

The dynamic voltage restorer works in three operating modes. They are (i) voltage compensating or active or injecting mode, (ii) standby mode, and (iii) fault current limiting or protecting mode. When the voltage disturbance occurs within the operating range of the DVR, at that instant, the bypass switch is open and DVR switches to active mode and feeds the grid with the required voltage. Once the voltage is in its normal range, the bypass switch will close and end the compensation mode. It is not necessary to inject voltage into the grid under normal conditions; hence, the DVR is left out through a bypass switch to reduce the power loss in the DVR by restricting the inverse effect on line voltage; this mode is known as the standby mode. Sometimes, high current flows through DVR due to SC fault on the load side which will cause damage to the injection transformer and DVR components; hence, the identification of downstream fault is necessary to protect the DVR [67]. The protection scheme of DVR is presented in Figure 10. It provides an alternative path to the fault current through breakers, thyristors, and varistors and ensures that the current path should be present. If the current path is not present, a severe overvoltage appears at the terminals of the injection transformer

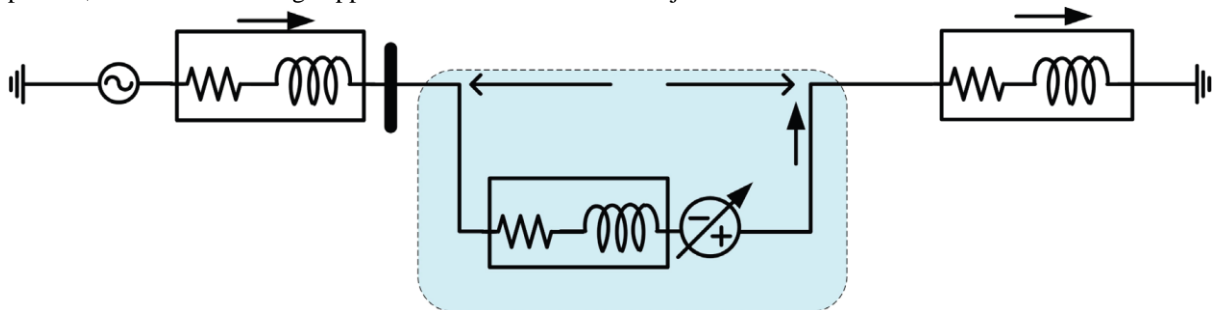

Basic structure of the dynamic voltage restorer

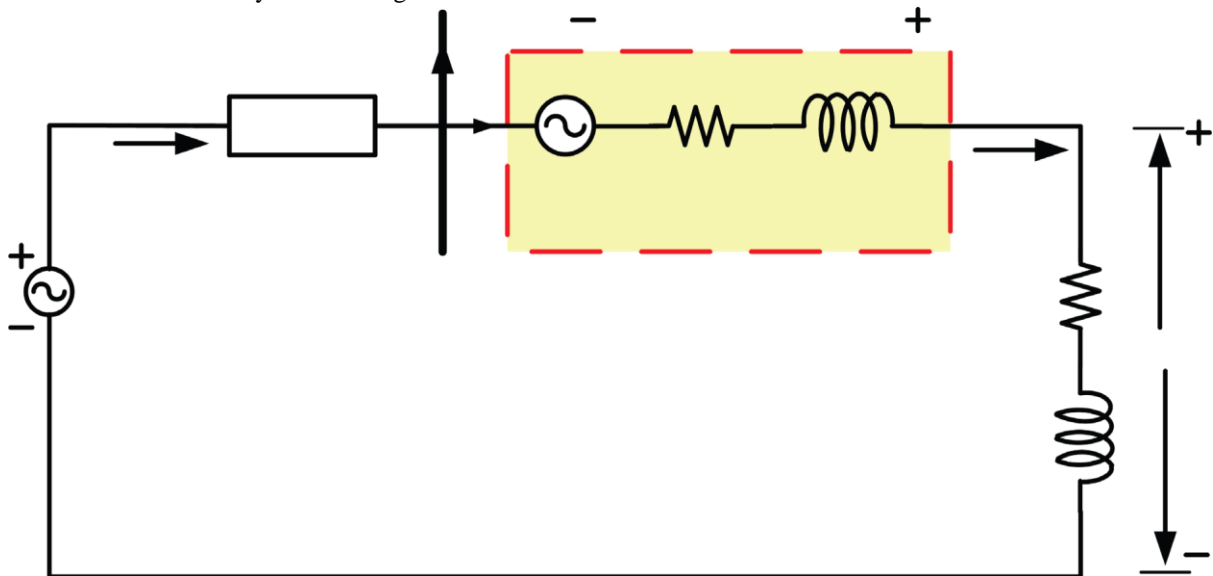

Equivalent model of the dynamic voltage restorer

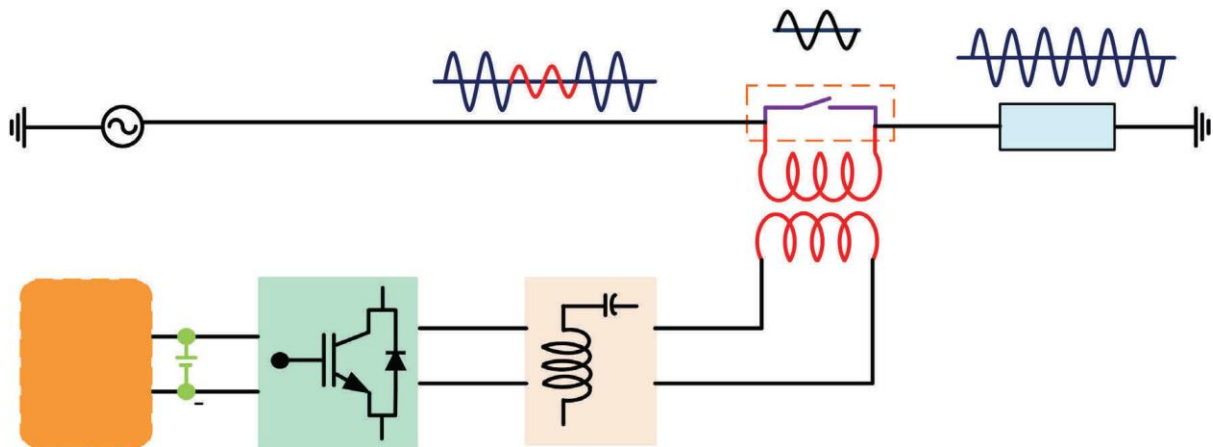

Schematic representation of 1 – ϕ DVR.

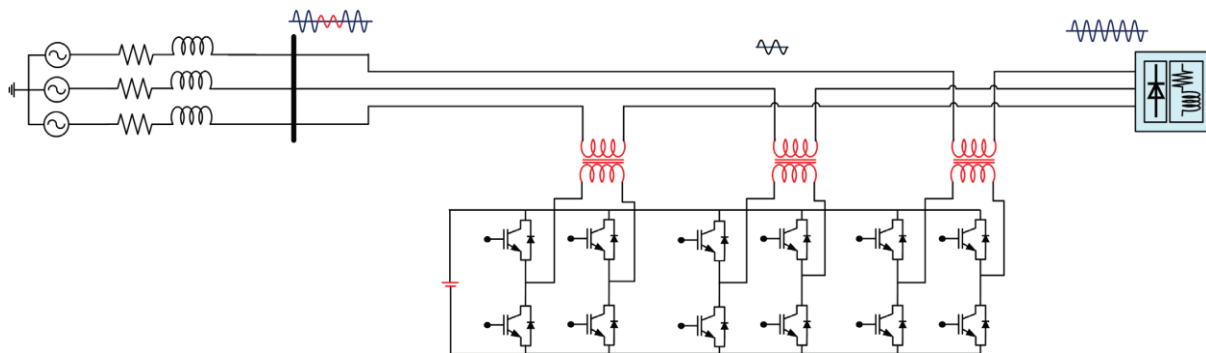

transformer connected to DVR
SIMULATION RESULTS:

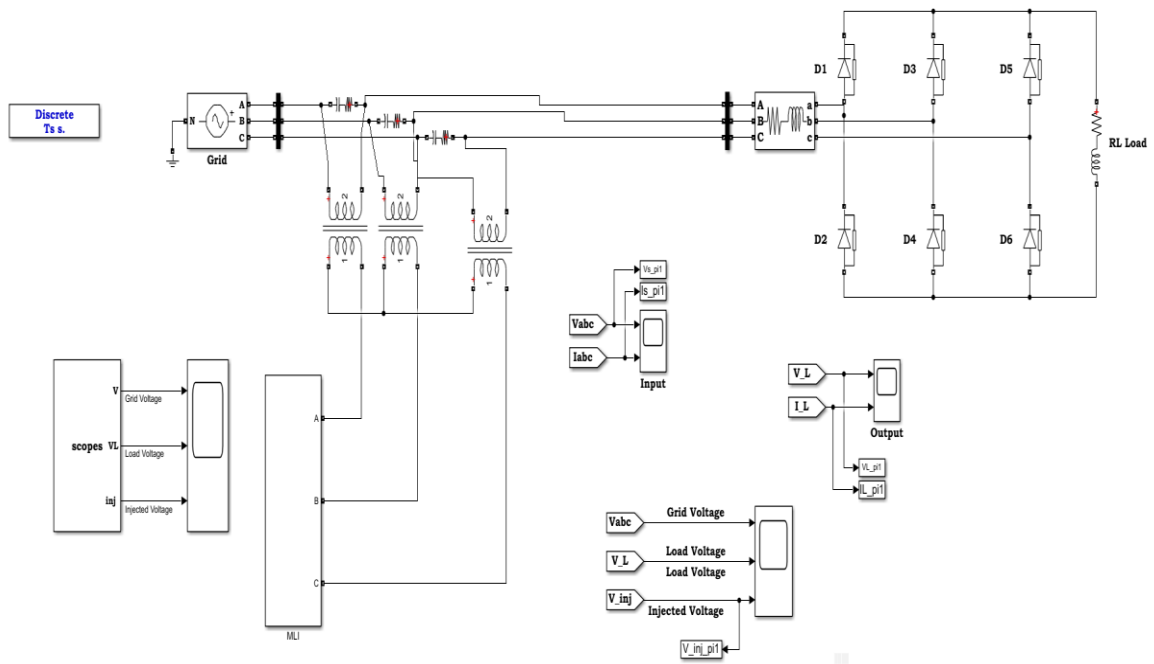

Fig: Simulation circuit

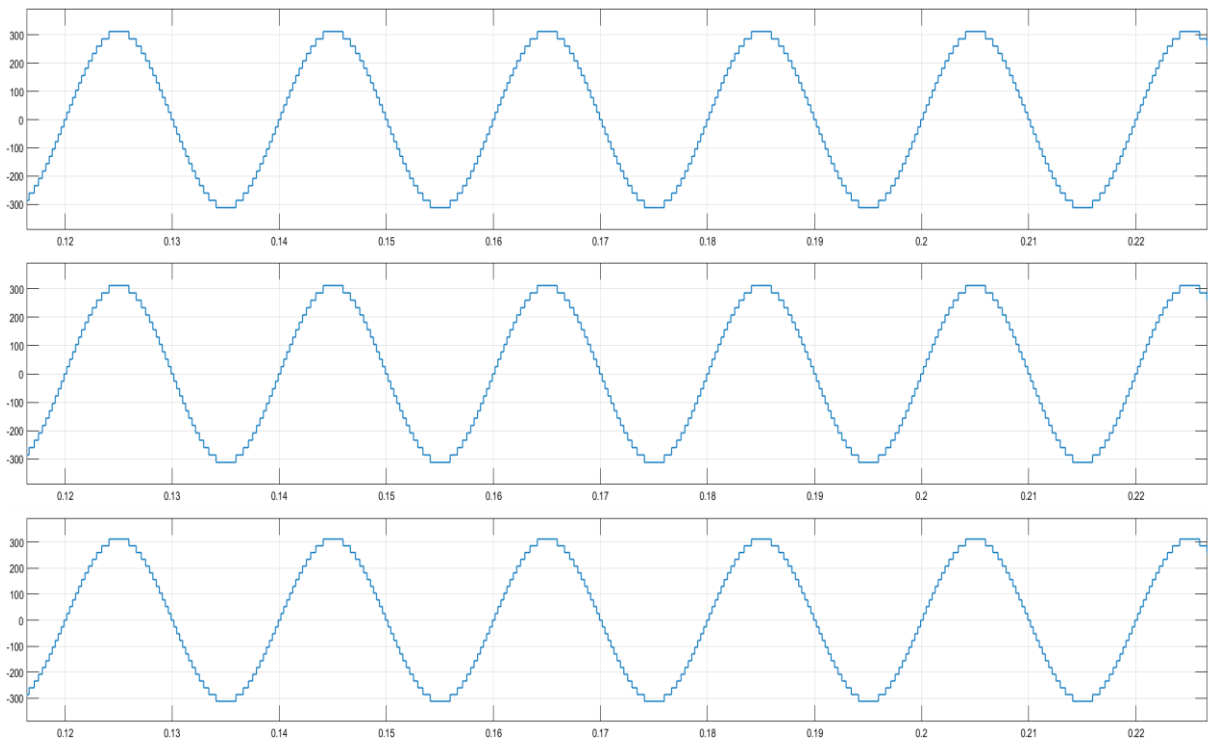

Fig: 23 level Inverter voltage

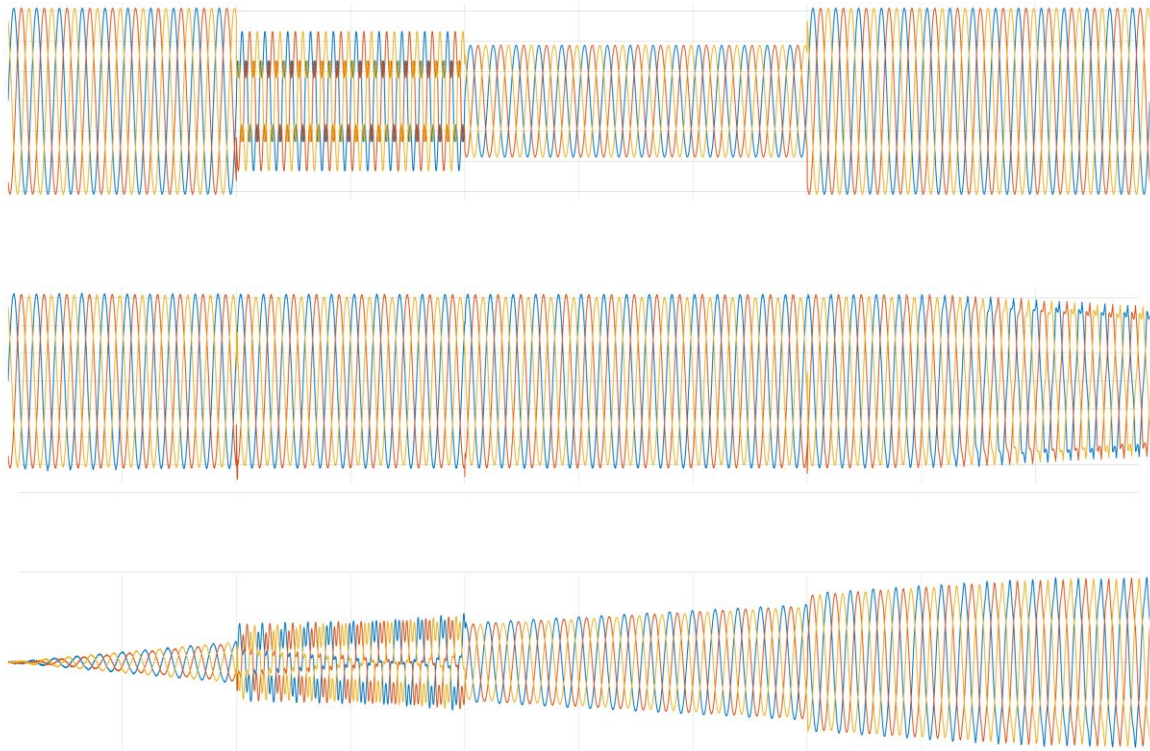
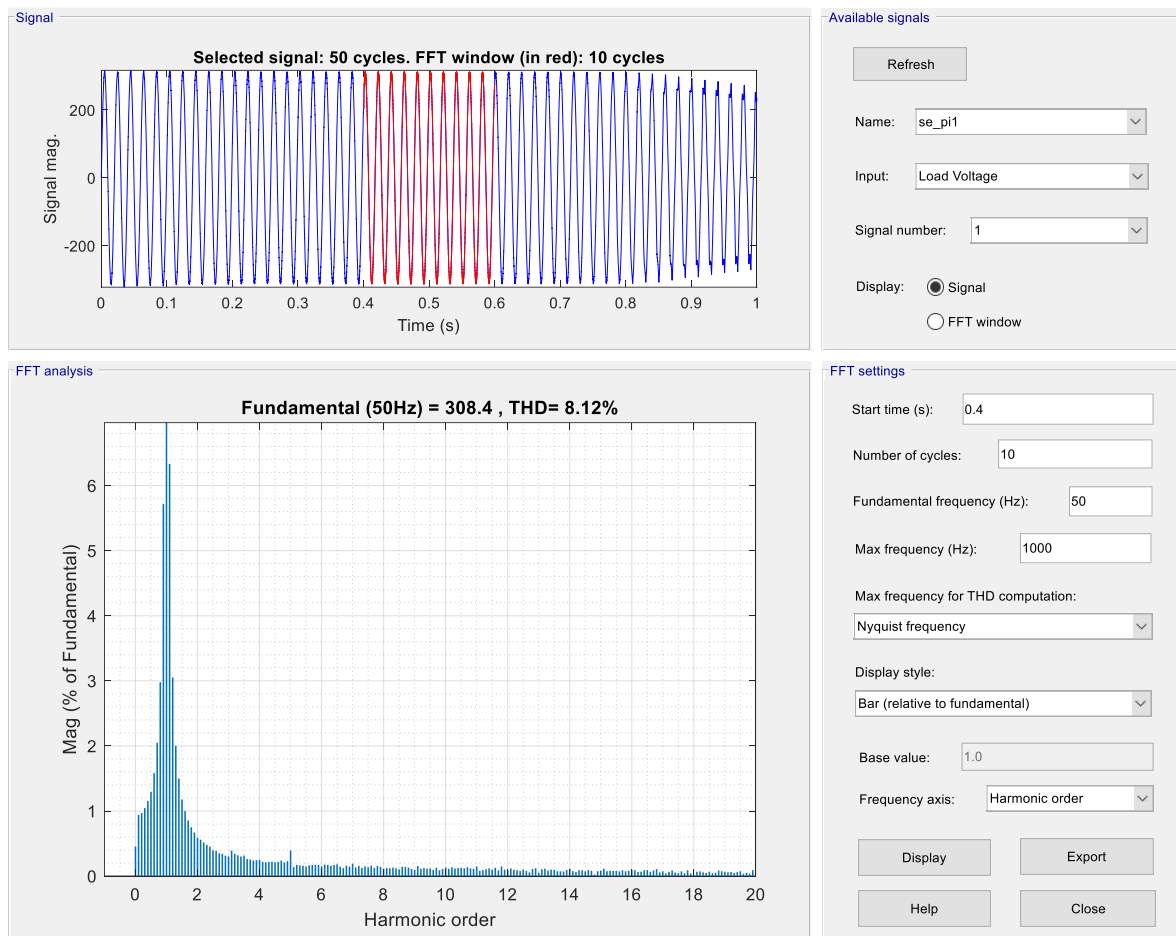

Fig: Grid voltage, load voltage and injected voltage

In the designed simulation for a 23-level Dynamic Voltage Restorer (DVR), the system's response to power quality disturbances is observed with high resolution. At the 0.2-second mark, a voltage sag occurs within the system, significantly dropping the line voltage below its nominal value. The DVR, equipped with an advanced control strategy, immediately identifies the deviation from the voltage threshold parameters. Utilizing its multilevel inverter structure, the DVR injects the precise compensating voltage required to correct the sag, restoring the load voltage to its pre-sag condition almost instantaneously.

Subsequently, at 1.2 seconds into the simulation, a voltage swell—a momentary increase in voltage—is introduced. This swell could potentially damage sensitive equipment connected to the grid. The DVR, monitoring the line conditions in real-time, detects this swell and dynamically adjusts the injected voltage levels to counteract the swell's effect. By subtracting the appropriate voltage, the DVR successfully clamps the load voltage back to its nominal level, thereby protecting the system's integrity. Both events showcase the DVR's capability to seamlessly provide voltage support and maintain power quality, affirming its critical role in modern electrical networks.



The integration of the series compensator with the solar PV-fed 23-level inverter has demonstrated a substantial improvement in the power quality of grid-connected systems. One of the most significant outcomes from the experimental and simulation studies is the reduction of the Total Harmonic Distortion (THD) to 8.12%. This value is considerably lower than the typical THD levels observed in grid-connected solar PV systems without such compensatory measures, which often exceed 15%.

This reduction in THD is critical for maintaining the integrity and efficiency of the electrical grid. High levels of harmonic distortion can lead to inefficient energy consumption, overheating of equipment, and potential operational failures. Thus, achieving a THD of 8.12% not only complies with most international standards for grid-connected systems, such as IEEE-519, which recommends a THD limit of less than 5% for voltage at the point of common coupling but also represents a significant step towards more sustainable and reliable solar PV installations.

Proposed 5 Level MLI:

The integration of a 5-level Multilevel Inverter (MLI) into the existing solar PV-fed system marks a pivotal enhancement aimed at further improving power quality, specifically in terms of reducing Total Harmonic Distortion (THD). Multilevel inverters are renowned for their ability to generate a closer approximation to a sinusoidal waveform, thereby minimizing harmonic distortion. The 5-level MLI, when combined with the 23-level inverter setup and series compensator, introduces additional voltage levels that allow for finer control over the output waveform, resulting in a more significant reduction in THD.

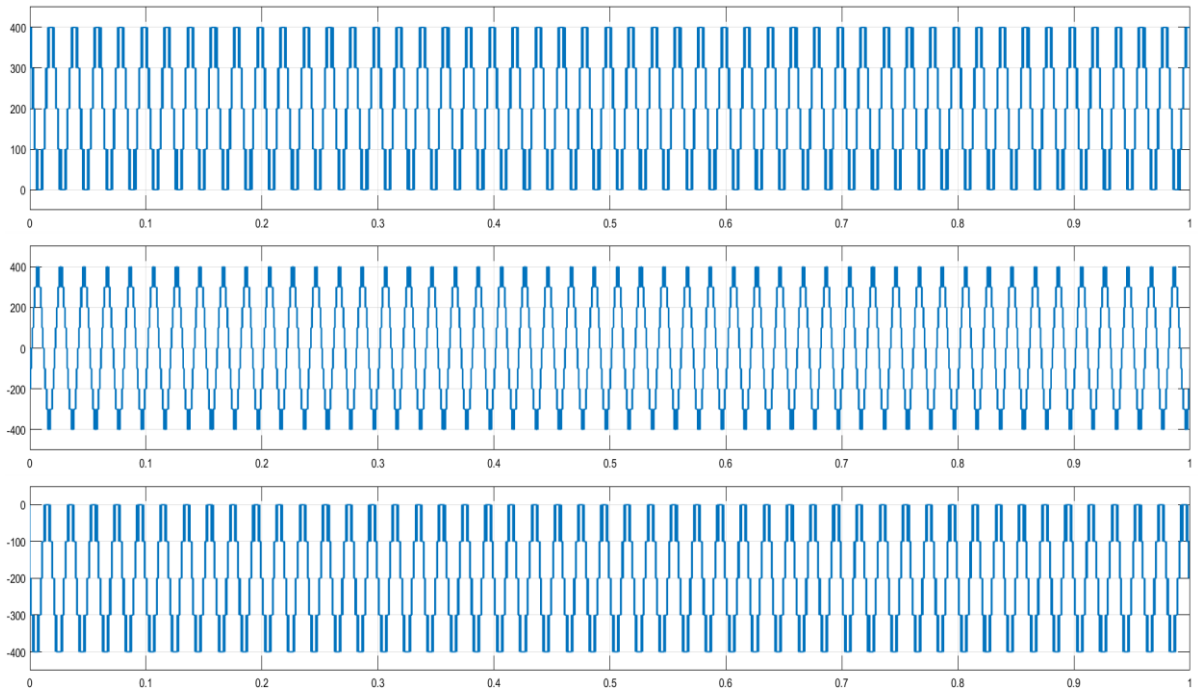

Proposed Five Level Voltage

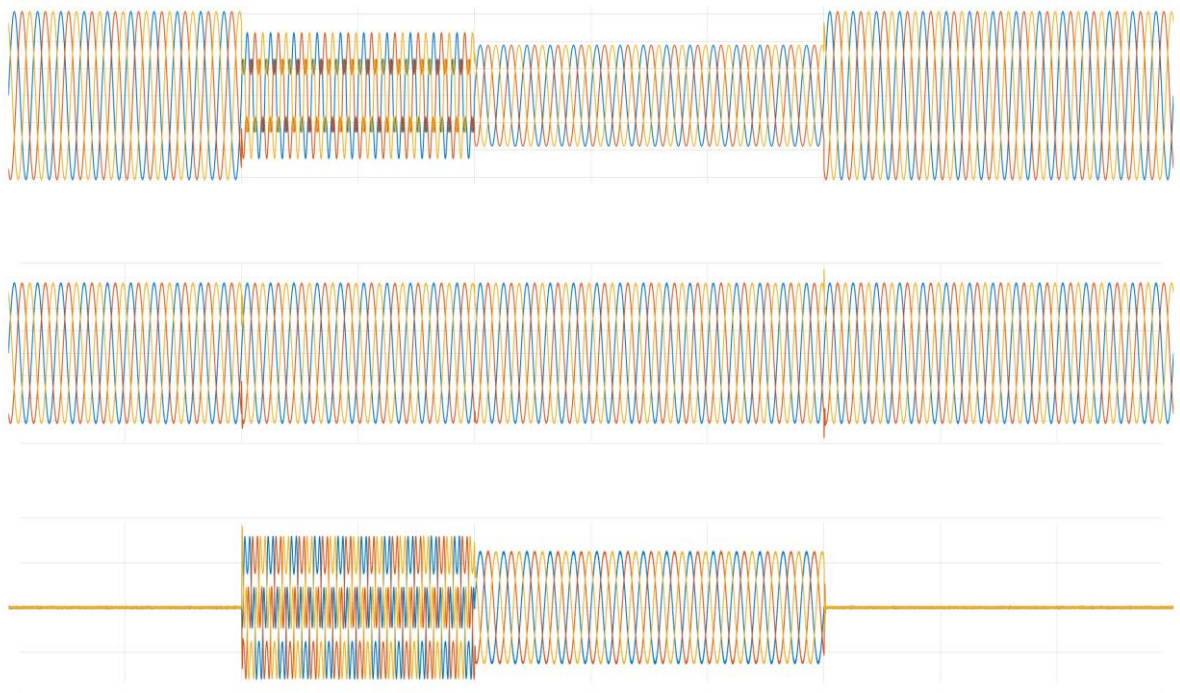
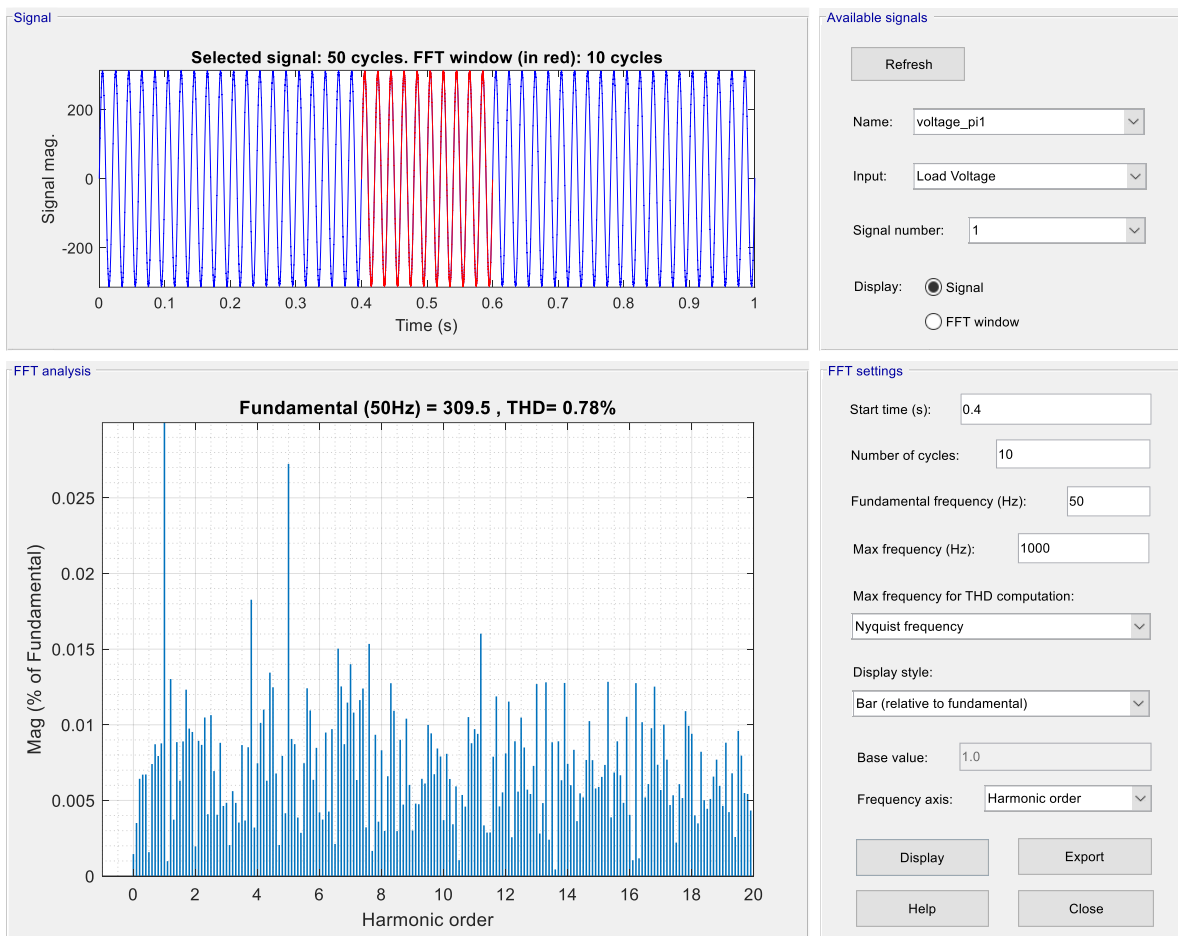

Fig: (a) Source voltage (b) Load voltage (c) Injected voltage



THD with proposed 5 level inverter

CONCLUSIONS:

A systematic review of different types of DVR systems and the future scope of the relevant literature are discussed in this article. Studies reviewing the DVR include many areas, but specifically, power quality issues, energy-storage topology, absence of energy, and controlled strategies are covered in this paper. DVR configurations based on power converters and control units at different stages are described in detail based on the latest literature. In the orientation towards the integration of renewable energy sources, certain updated and upgraded DVR configurations are also presented. This review supports the selection of the best, mostcost-effective, and high-performance DVR configurationbased on the requirements of researchers and scientistsworking on this prospective research

References:

- [1] N. H. Woodley, L. Morgan, and A. Sundaram, "Experience with an inverter-based dynamic voltage restorer," *IEEE Transactionson Power Delivery*, vol.14,no.3,pp.1181–1186, 1999.
- [2] K.R.Padiyar, *FACTS Controllersistin Power Transmissionand Distribution*, New Age International(P) Limited, Publishers, Chennai, Tamil Nadu, 2007.
- [3] A. Moghassemi and S. Padmanaban, "Dynamic voltage re- storer (DVR): acomprehensive review of topologies, power converters, control methods, and modified configurations," *Energies*, vol. 13, no. 16, p. 4152, 2020.

- [4] B. P. Babu and V. Indragandhi, “A review on dynamic voltage restorer in power systems concerned to the issues of power quality IOP conference series: materials science and engineering,” *IOP Publishing*, vol. 623, no. 1, Article ID 012015, 2019.
- [5] J. Praveen, B. P. Muni, S. Venkateshwarlu, and H. V. Makthal, “Review of dynamic voltage restorer for power quality improvement,” vol. 1, pp. 749–754, in *Proceedings of the 30th Annual Conference of IEEE Industrial Electronics Society, 2004. IECON 2004*, vol. 1, pp. 749–754, IEEE, Busan, Korea (South), November 2004.
- [6] V. K. Remya, P. Parthiban, and V. Ansal, “Dynamic Voltage Restorer (DVR) – a review,” *Journal of Green Engineering*, vol. 8, 2018.
- [7] M. Farhadi-Kangarlu, E. Babaei, and F. Blaabjerg, “A comprehensive review of dynamic voltage restorers,” *International Journal of Electrical Power & Energy Systems*, vol. 92, pp. 136–155, 2017.
- [8] M. A. El-Gammal, A. Y. Abou-Ghazala, and T. I. El-Shennawy, “Fifteen years of the dynamic voltage restorer: a literature review,” *Australian Journal of Electrical and Electronics Engineering*, vol. 8, no. 3, pp. 279–287, 2011.
- [9] Iea, *Global Energy Review 2021*, IEA, Paris, 2021.
- [10] Iea, *Renewable Energy Market Update 2021*, IEA, Paris, 2021.
- [11] H. X. Li, D. J. Edwards, M. R. Hosseini, and G. P. Costin, “A review on renewable energy transition in Australia: an updated depiction,” *Journal of Cleaner Production*, vol. 242, Article ID 118475, 2020.
- [12] A. Battaglini, J. Lilliestam, A. Haas, and A. Patt, “Development of SuperSmart Grids for a more efficient utilisation of electricity from renewable sources,” *Journal of Cleaner Production*, vol. 17, no. 10, pp. 911–918, 2009.
- [13] A. Q. Al-Shetwi, M. Hannan, K. P. Jern, M. Mansur, T. Mahlia, and T. M. I. Mahlia, “Grid-connected renewable energy sources: review of the recent integration requirements and control methods,” *Journal of Cleaner Production*, vol. 253, Article ID 119831, 2020.
- [14] T. R. Ayodele, A. Jimoh, J. L. Munda, and J. T. Agee, “Challenges of grid integration of wind power on power system grid integrity: a review,” *World*, vol. 3, no. 6, pp. 618–626, 2020.
- [15] E. Hossain, M. R. Tur, S. Padmanaban, S. Ay, and I. Khan, “Analysis and mitigation of power quality issues in distributed generation systems using custom power devices,” *IEEE Access*, vol. 6, pp. 16816–16833, 2018.
- [16] A. Shetwi, Q. Ali, S. M. Zahim, and R. N. Lina, “A review of the fault ride through requirements in different grid codes concerning penetration of PV system to the electric power network,” *ARPJ: Journal of Engineering and Applied Sciences*, vol. 10, no. 21, pp. 9906–9912, 2015.

- [17]H.Bevrani, H.Golp[^]ira, A.R.Messina, N.Hatziargyriou ,F. Milano, and T. Ise, “Power system frequency control: an updated review of current solutions and new challenges,” *Electric Power Systems Research*, vol.194, Article ID 107114, 2021.
- [18]M.Sedighzadeh, M.Esmaili, and S.M.Mousavi-Taghiabadi, “Optimal energy and reserve scheduling for power systems considering frequency dynamics, energy storage systems and windturbines,”*JournalofCleanerProduction*,vol.228, pp.341–358,2019.